

The background is a dark blue color with a pattern of concentric circles in a lighter shade of blue, resembling a target or ripple effect. A large white circle is centered on the page, containing the main title text. The text is in a bold, sans-serif font. The word 'RECOIL' is in black, while 'TARGET' and 'PACK' are in a dark grey color. There are small white tick marks on the left and right sides of the white circle.

# **RECOIL TARGET PACK**

**50+ DOWNLOADABLE TARGETS**

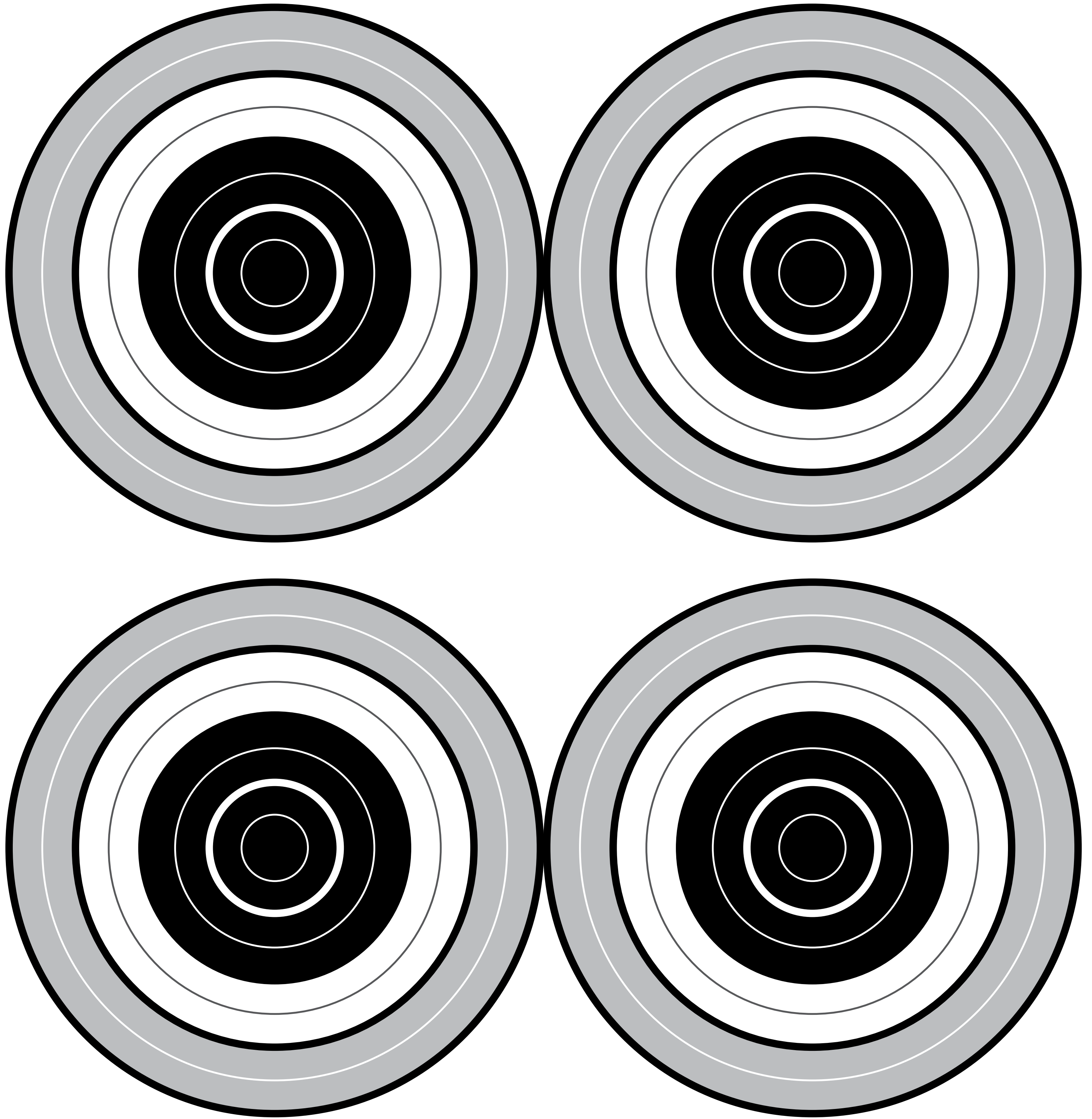

**RECOIL**

[www.hd-inc.com/remington](http://www.hd-inc.com/remington)

 **Remington**  
WHEELS FOR THE TRUE OUTDOORSMAN.



designs



Target Focus



Front Sight Focus

SIGHT ADJUSTMENT

Aimpoint®: 1/2 MOA  
EDTech: 1/2 MOA  
Trijicon ACOG®: 1/2 MOA

Quarter Minute of Angle (1/4 MOA)

	25 yds	50 yds	100 yds
4 clicks	0.25 in	0.50 in	1.00 in
8 clicks	0.50 in	1.00 in	2.00 in
16 clicks	1.00 in	2.00 in	4.00 in

Half Minute of Angle (1/2 MOA)

	25 yds	50 yds	100 yds
4 clicks	0.50 in	1.00 in	2.00 in
8 clicks	1.00 in	2.00 in	4.00 in
16 clicks	2.00 in	4.00 in	8.00 in

www.falconops.net

FOG-TG002-P01

© Copyright 2012 Philip Jason Antonucci

Original target created for Falcon Operations Group. FOG-TG002-P01 is an adjusted promotional piece based on the original design of Aggressive Combat Threat Target (FOG-TG002), currently available for sale at www.letargets.com. Rights to all graphic elements reserved by the designer, Philip J Antonucci. Additional information on this target available from Falcon Operations Group and/or www.letargets.com.

For information regarding this or other custom target designs, please contact the designer directly at: retrorsine@gmail.com. Available for hire; no cost consultations.

Bullet Trajectory & Point of Impact (POI)

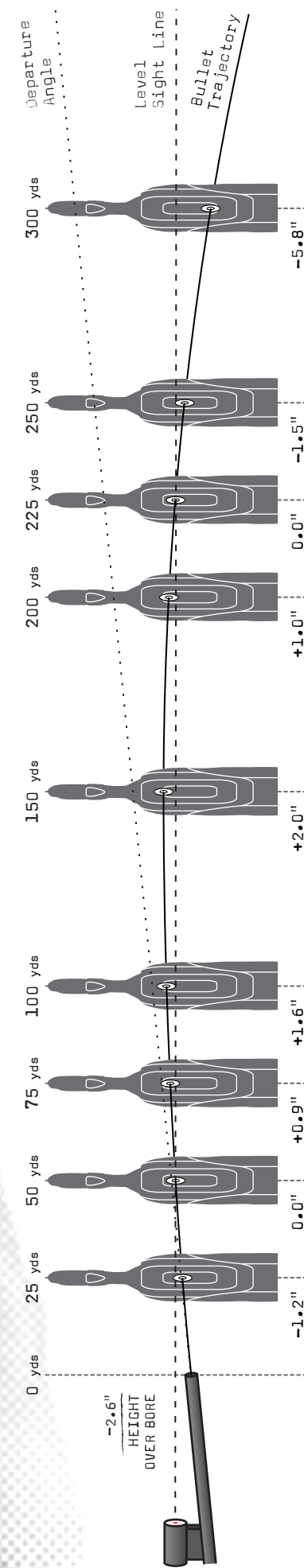

Ballistic data obtained from US Marine ballistic charts. Graphic represents results of a 5.56mm M193 cartridge with 55gr ball projectile fired from a standard 16" M4 producing a muzzle velocity of 2700 fps.

RECOIL

FALCON OPERATIONS GROUP

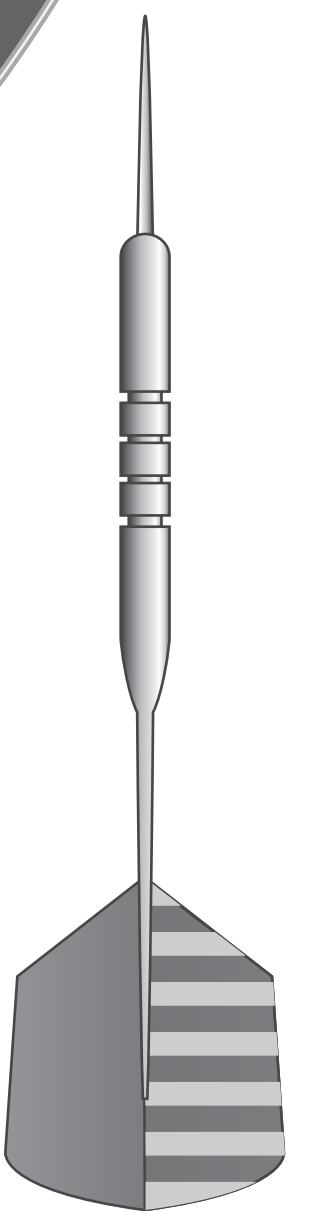
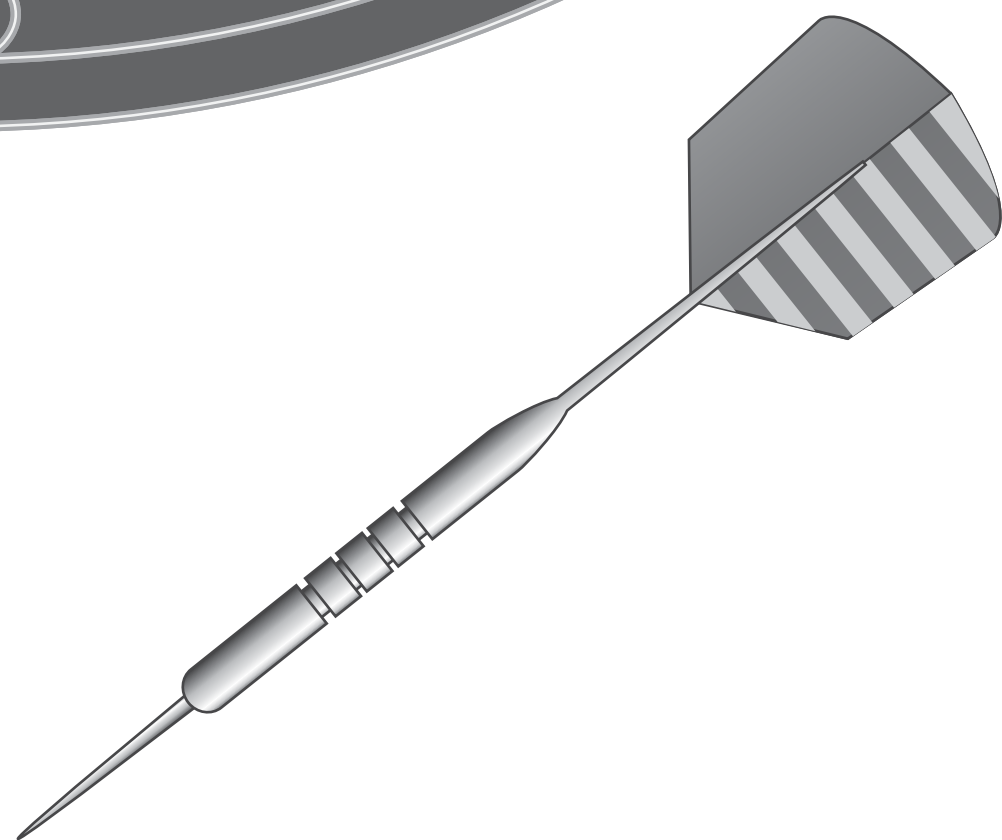
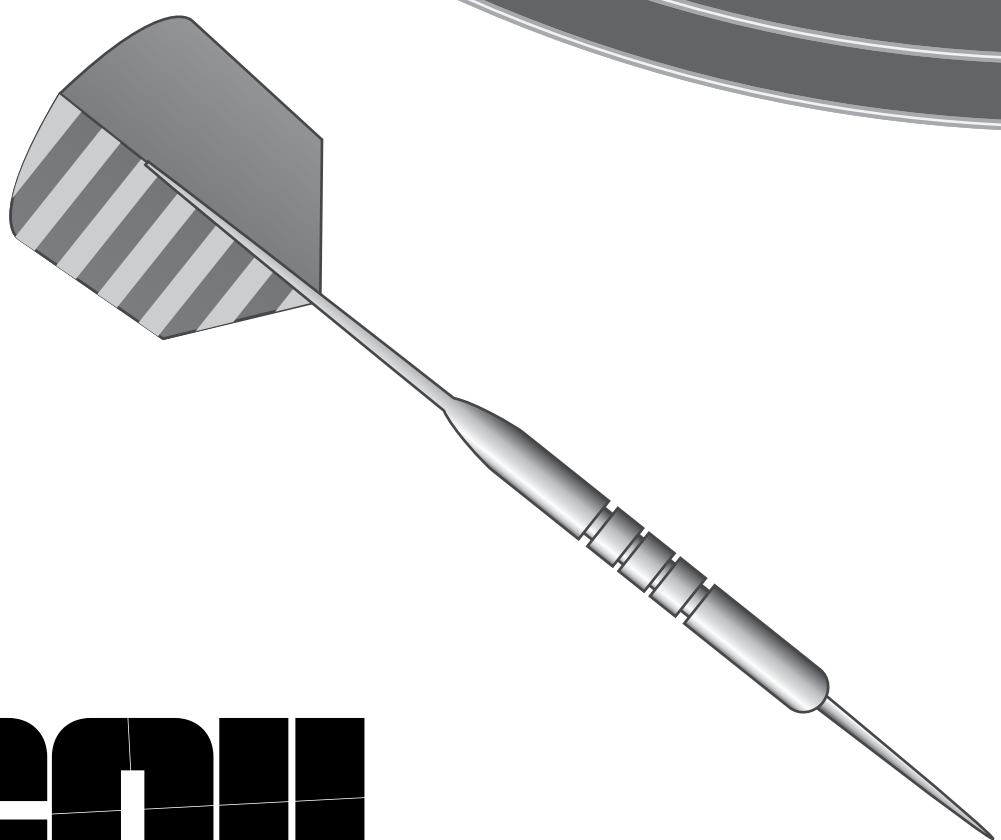
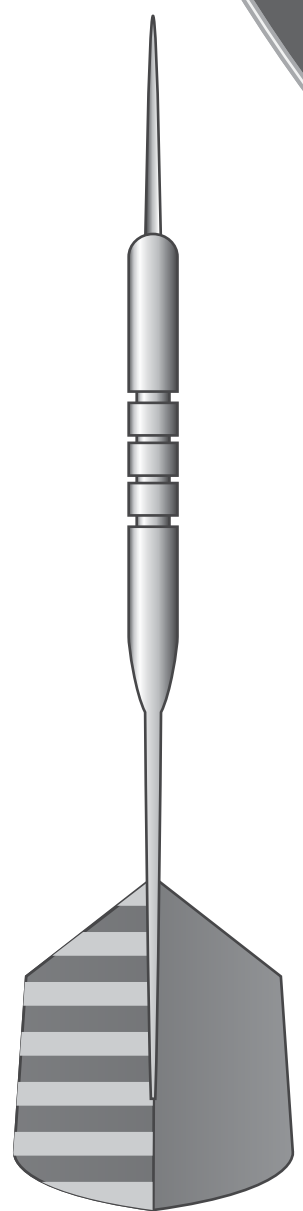
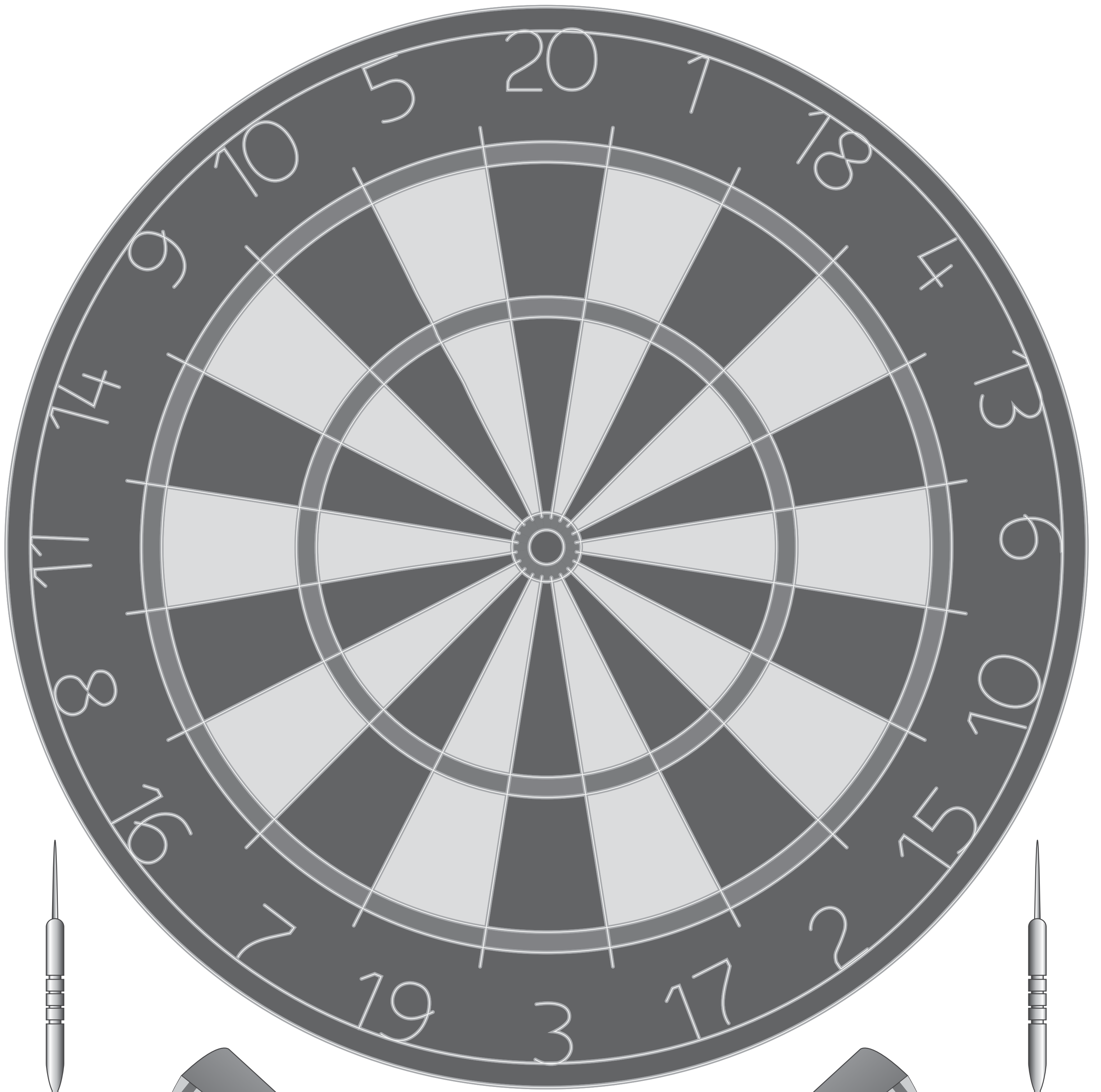

**RECOIL**

[www.recoilweb.com](http://www.recoilweb.com)

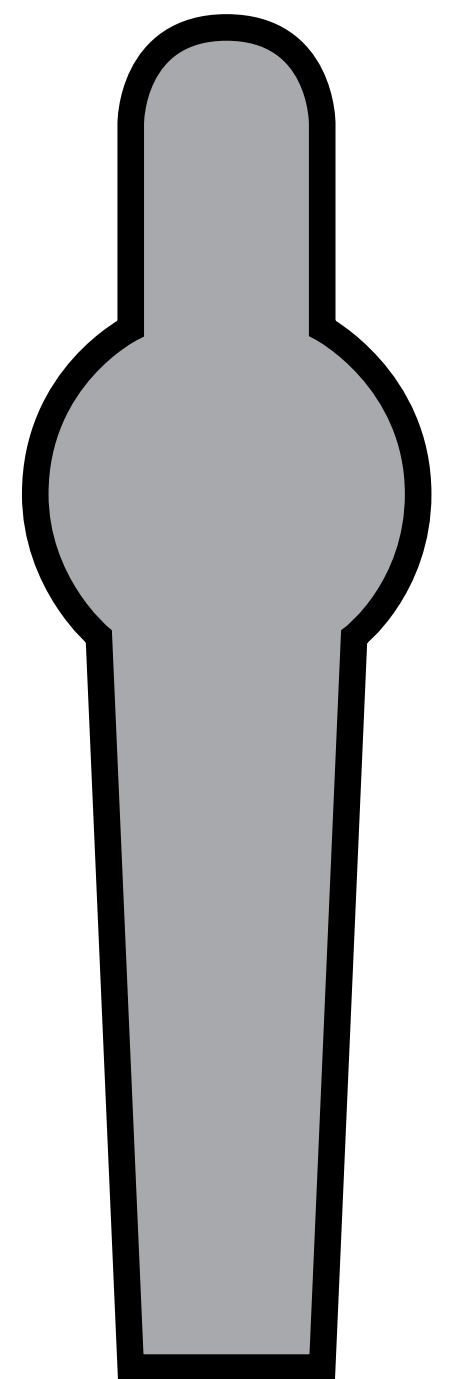
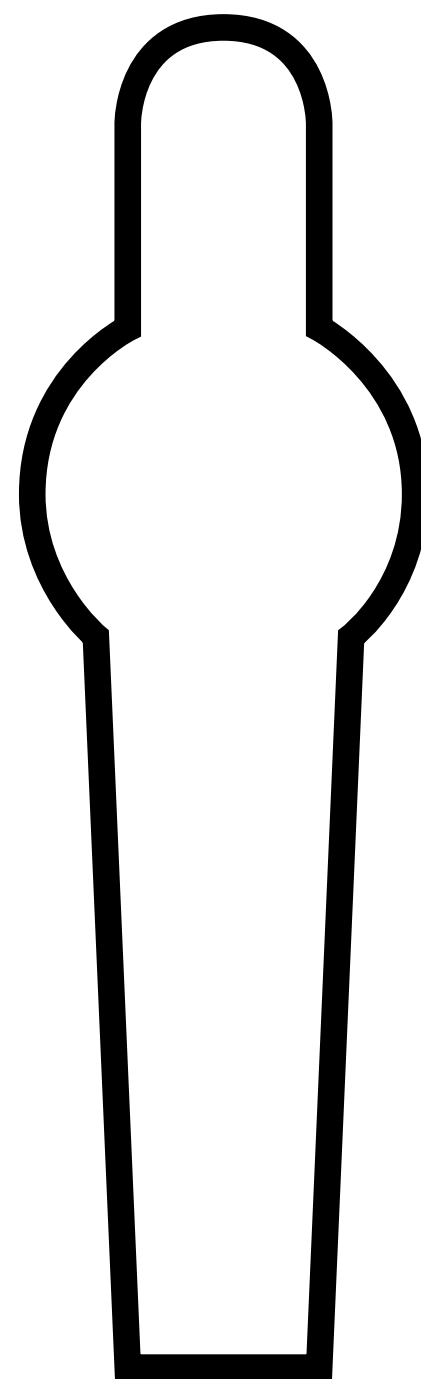
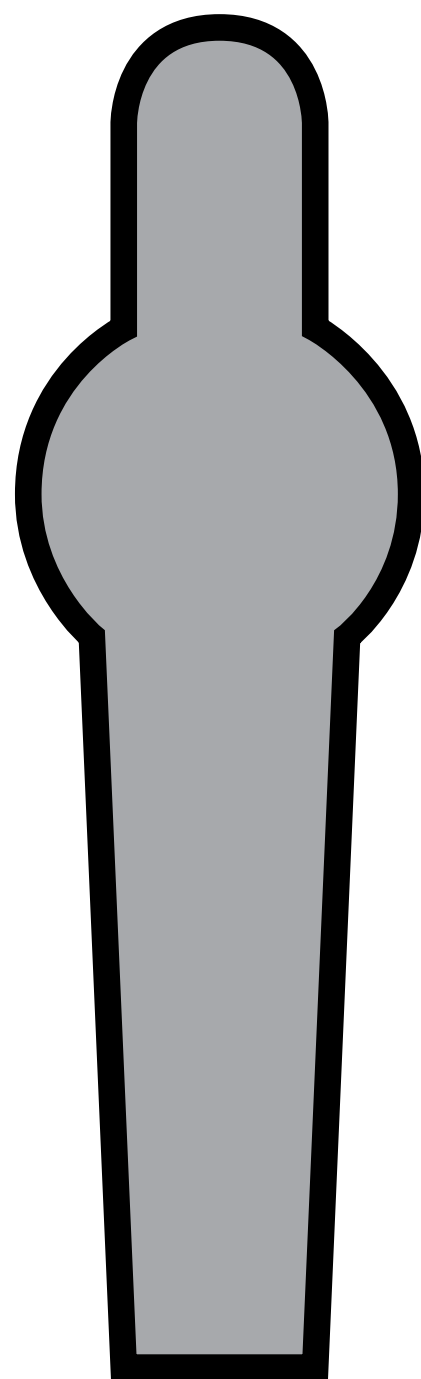
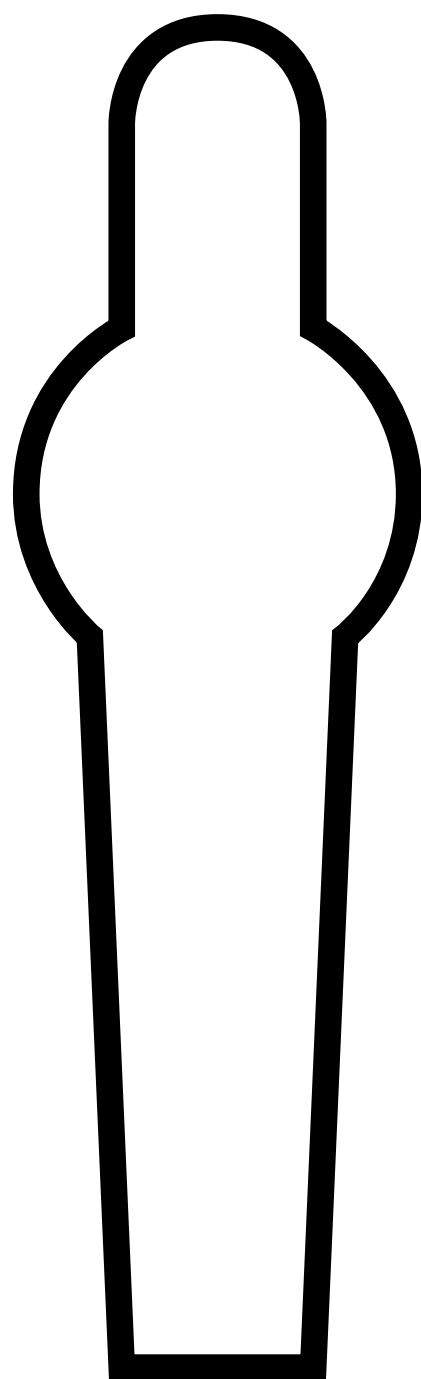
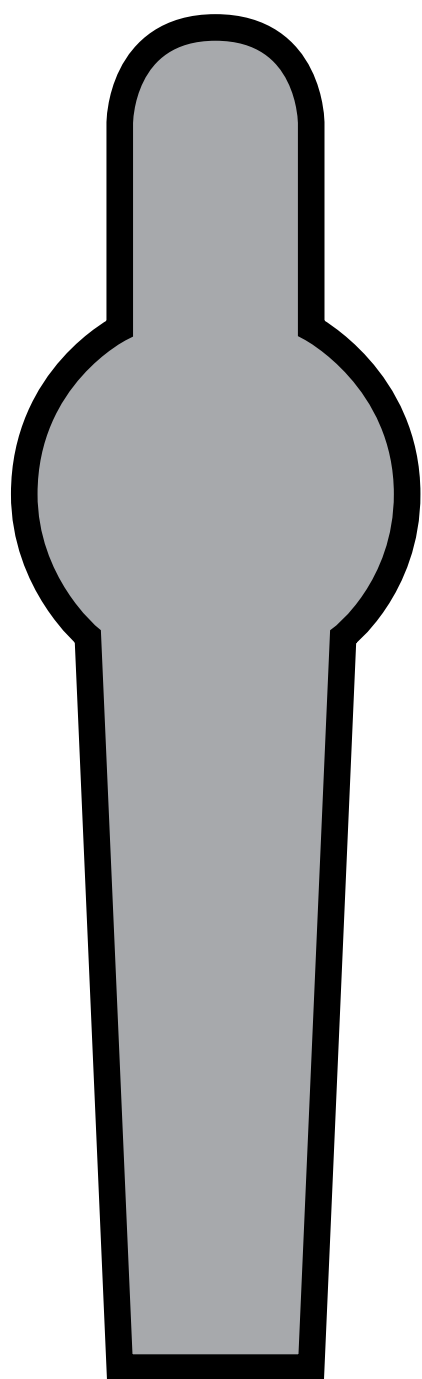
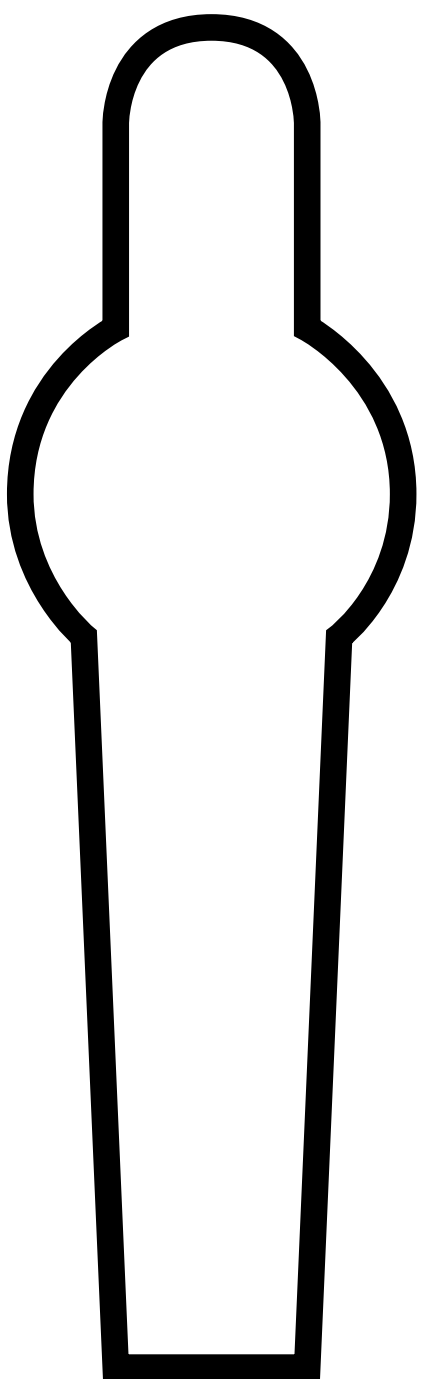
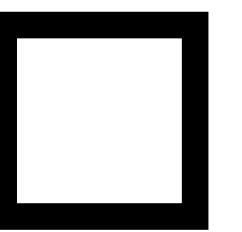
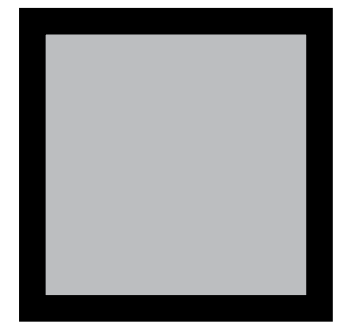
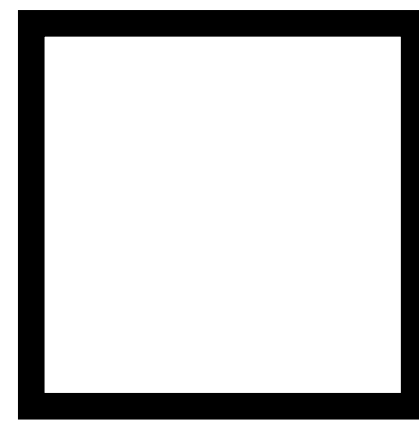
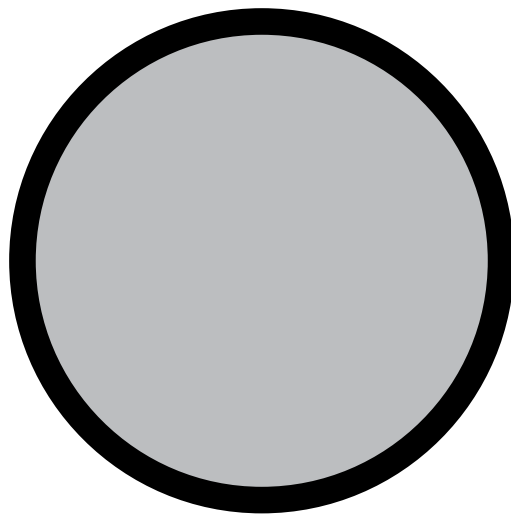
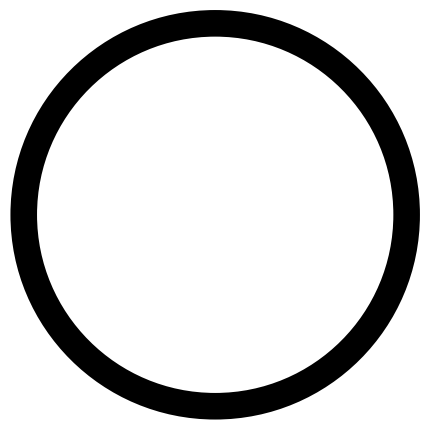
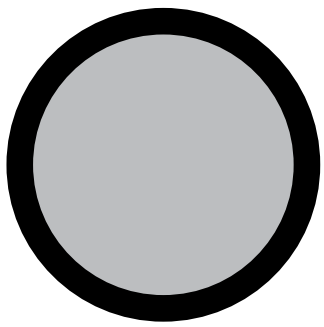
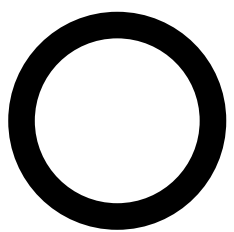
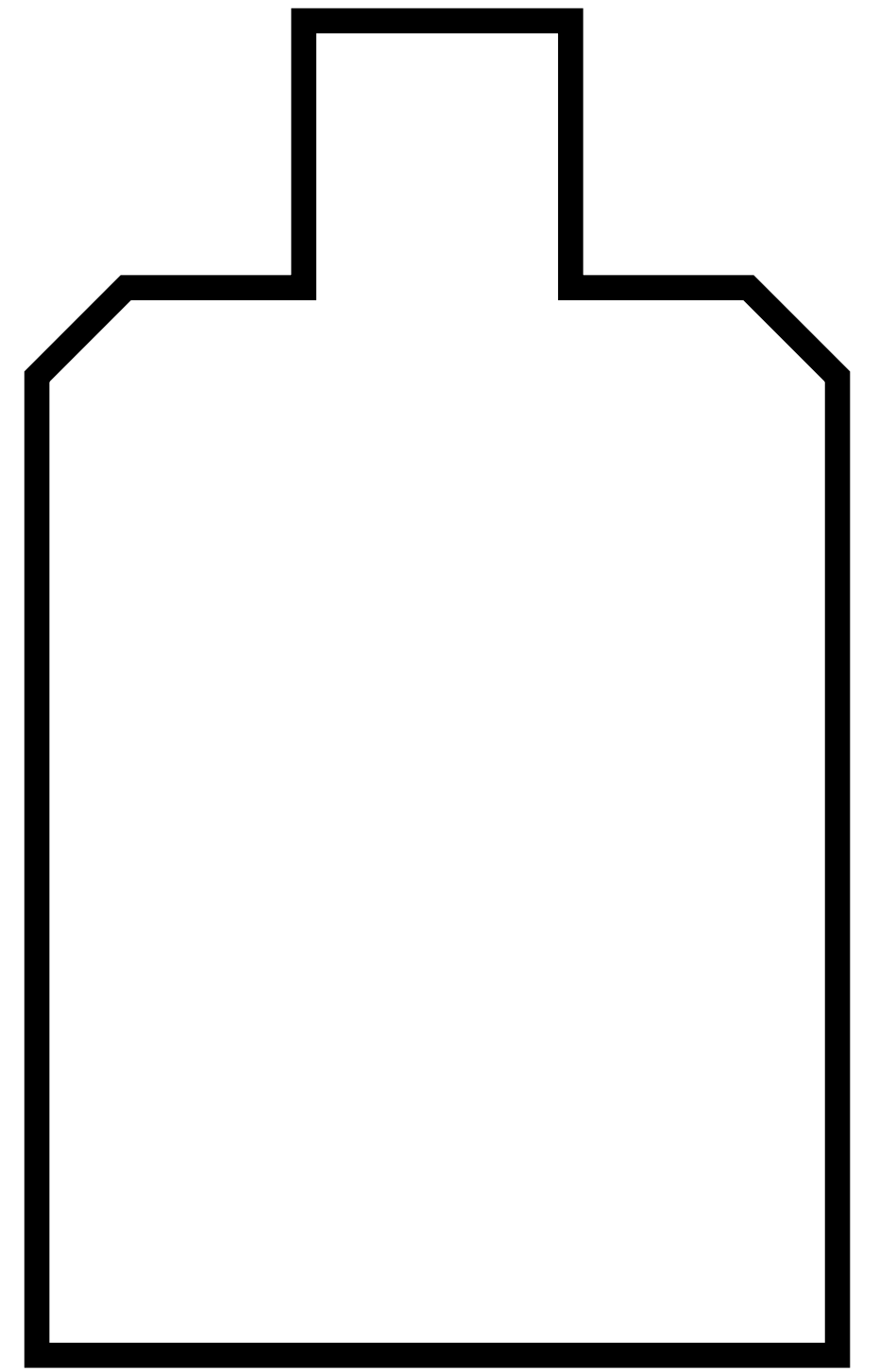
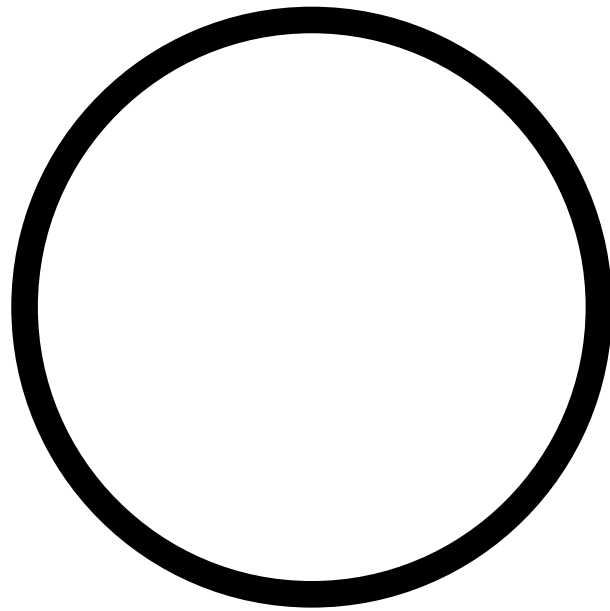
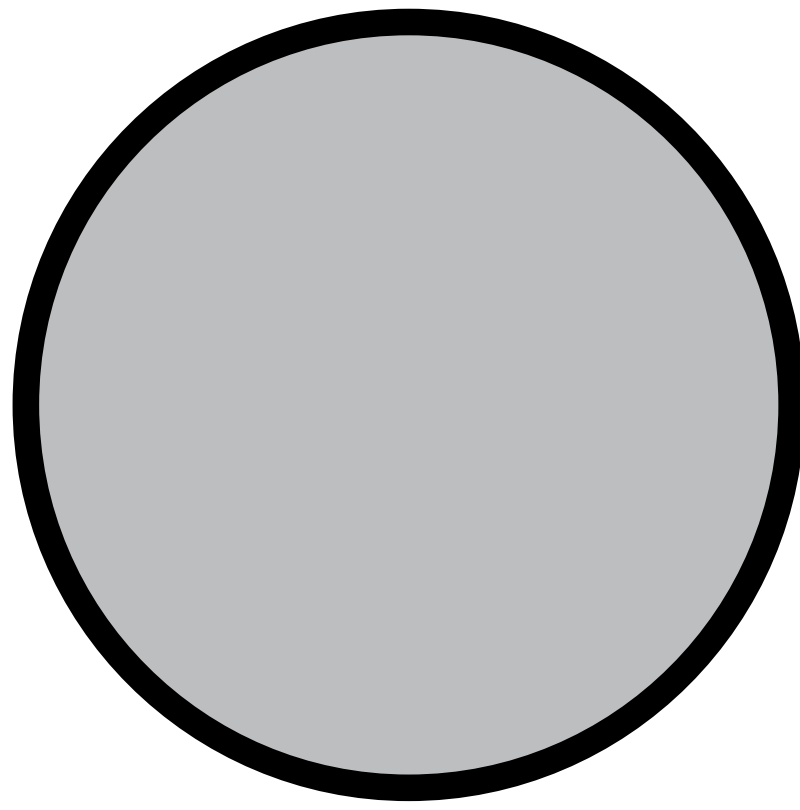
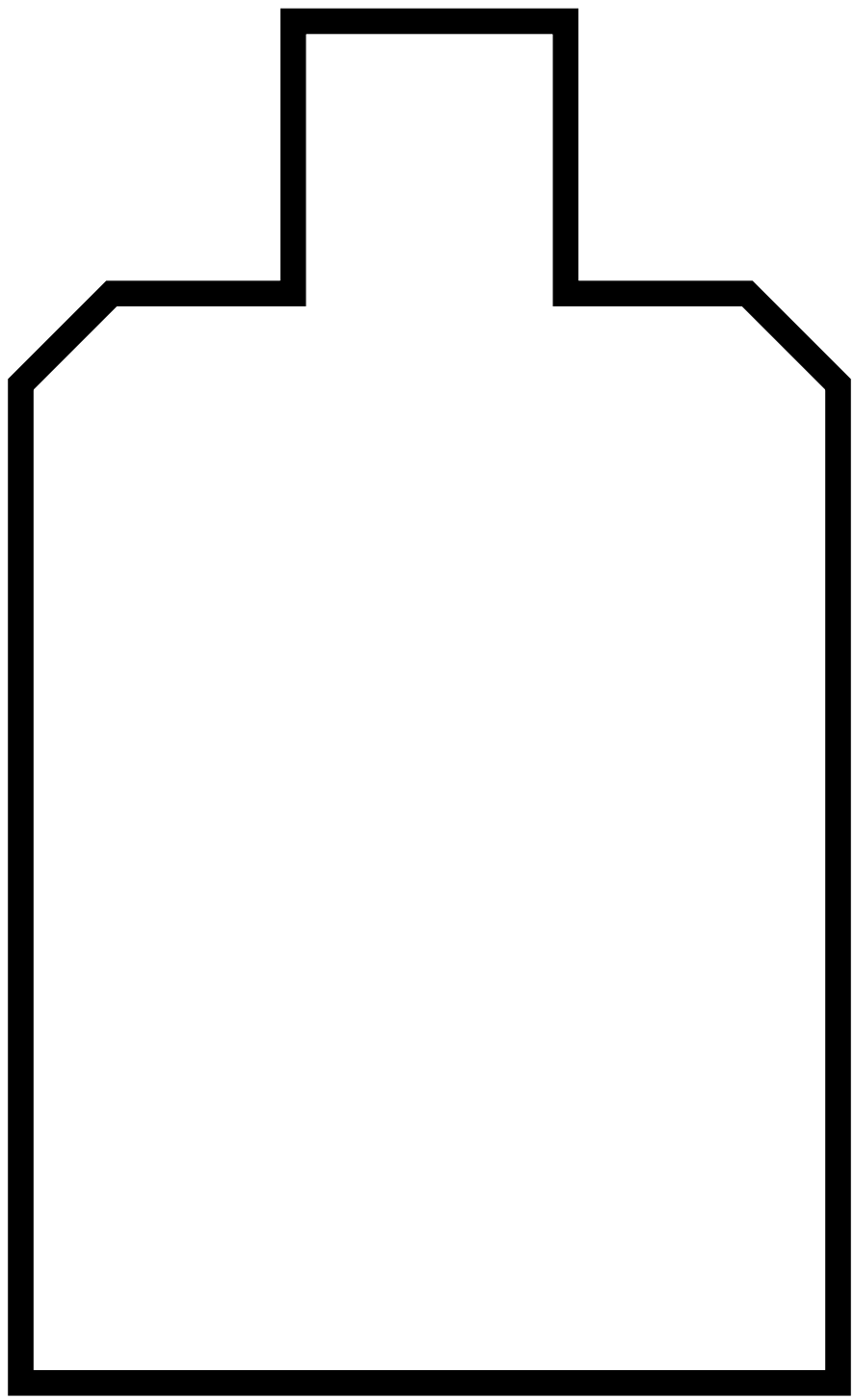

**RECOIL**

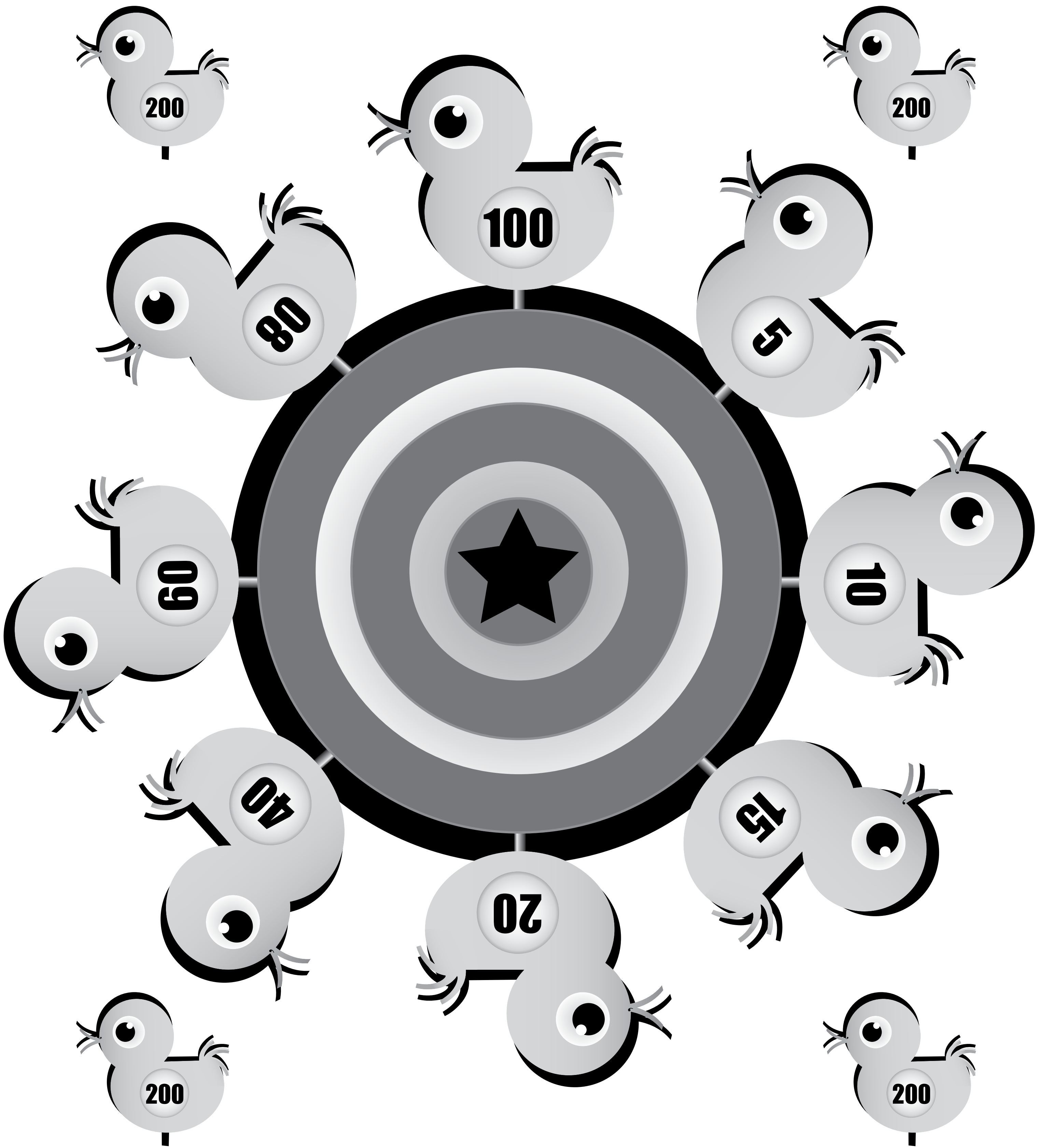

**RECOIL**

[www.recoilweb.com](http://www.recoilweb.com)



**RECOIL**

[www.facebook.com/falkentire](http://www.facebook.com/falkentire)

**FALKEN**  
TIRE

WE GET YOU GOING™



**RECOIL**

[www.recoilweb.com](http://www.recoilweb.com)



# RECOIL



0	3	6	9	12	15	18	21	24	27	30	33	36
1	2	5	8	11	14	17	20	23	26	29	32	35
4	7	10	13	16	19	22	25	28	31	34	RECOIL	

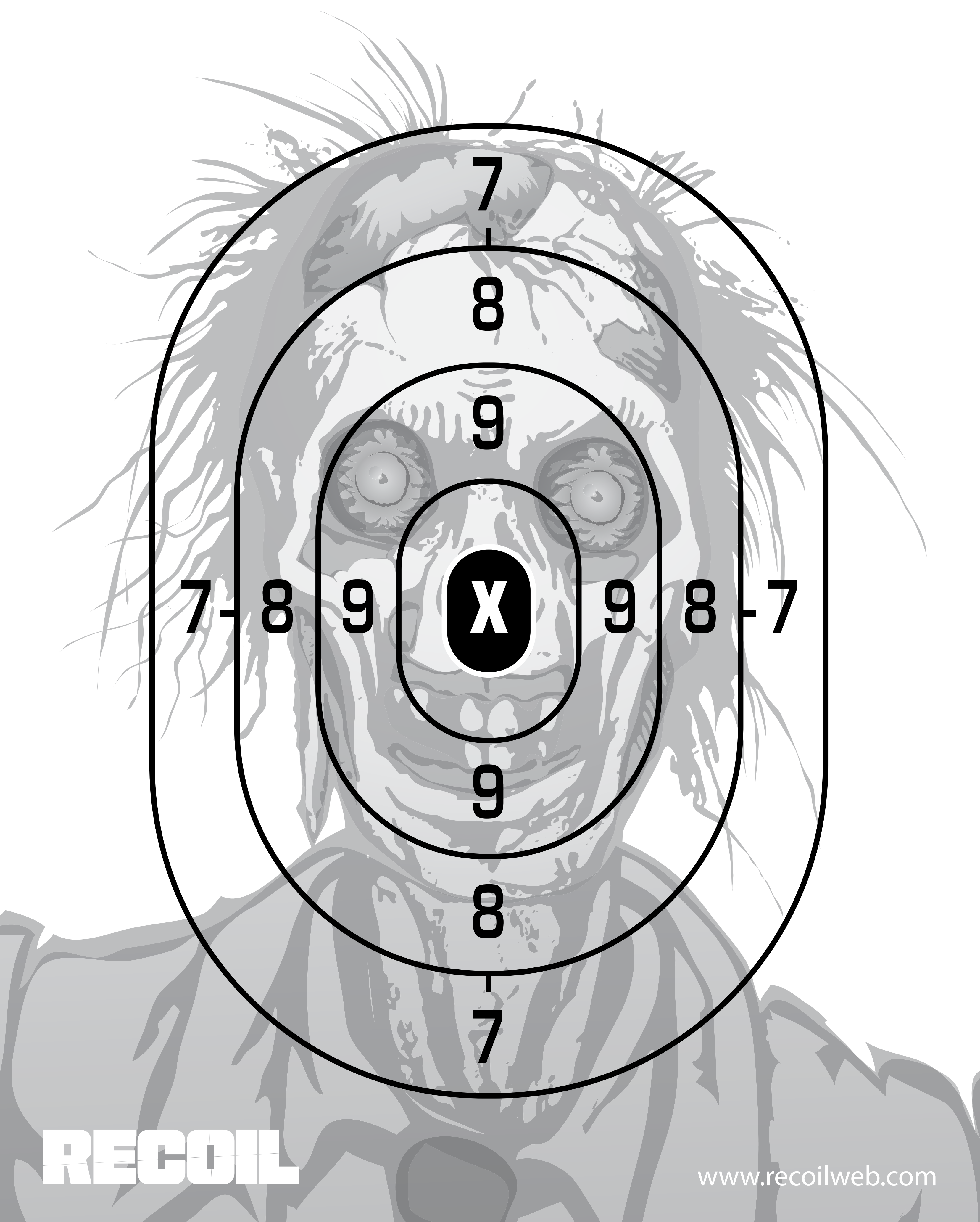

**RECOIL**

[www.recoilweb.com](http://www.recoilweb.com)



**RECOIL**

**SPIKES TACTICAL.COM**





**RECOIL**

**WWW.RECOILWEB.COM**

# Gotta shoot 'em all!



# RECOIL

[WWW.RECOILWEB.COM](http://WWW.RECOILWEB.COM)



Show off your target shooting with a RECOIL target!  
Take a photo of your RECOIL target through Instagram with the hashtag #recoiltarget  
for a chance to be submitted in the gallery!\*

\* Images approved at our discretion.

# #getyourslingon

## DRILL 1



1. **Set up your target** at a distance of 25 yards. Load 15 rounds into your magazine.
2. **Engage the top bullseye** – with your rifle unslung, attempt three five-shot groups in the following positions: standing, kneeling, and prone
3. **Score the target** with each shot being worth up to 10 points. If a shot lands on a line, give yourself the higher score. Maximum score possible is 150 points (i.e. 15 times 10).

# RECOIL

## DRILL 2



1. **Repeat the same drill with a second bullseye using the sling as a support.** Specifically, adjust the closed loop on the front of the sling so you can cinch it tight around your bicep, then tightly grip the fore end using the sling to lock the front of the rifle into place. The sling will most likely need to either hang loose or be detached from its rear attachment point (like other military-style slings that are used as shooters aids, such as the M1907 sling). You may need to experiment with the sling in order to acquire the most comfortable and stable position.
2. **Then compare your score** between the two drills – you should see improved scores in all three positions.

 **BLUE FORCE GEAR**<sup>®</sup>  
[blueforcegear.com](http://blueforcegear.com)

*Recoil*

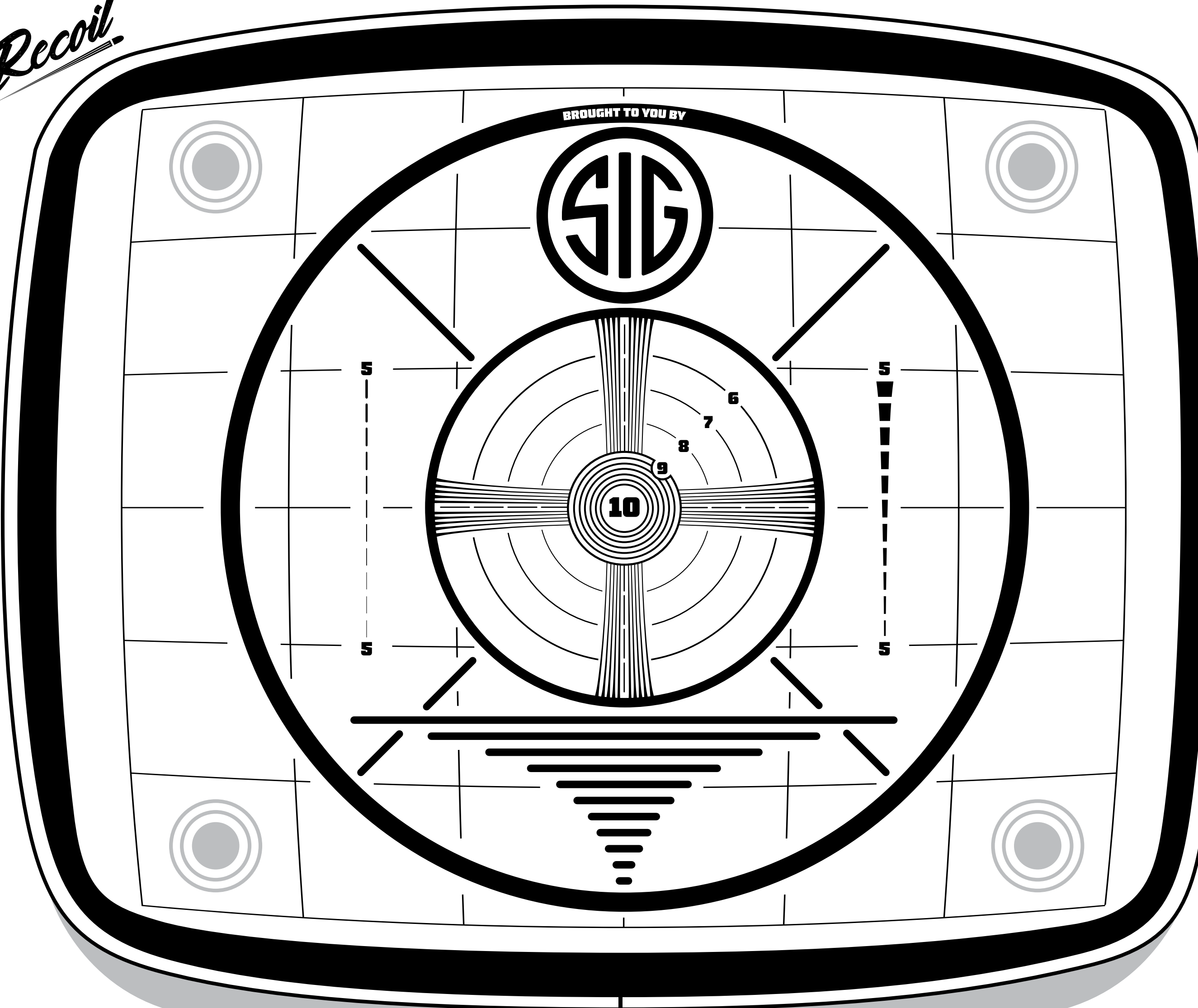

SPONSORED BY

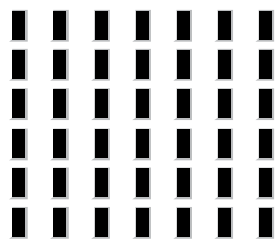

UHF

BBC RSC ITA ITA

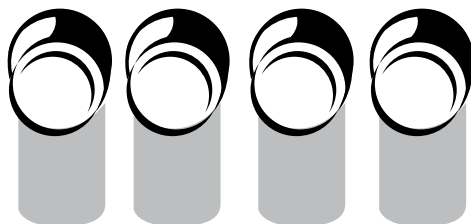

OFF

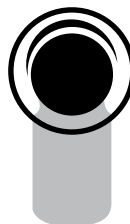

VOL



BRI



VHF

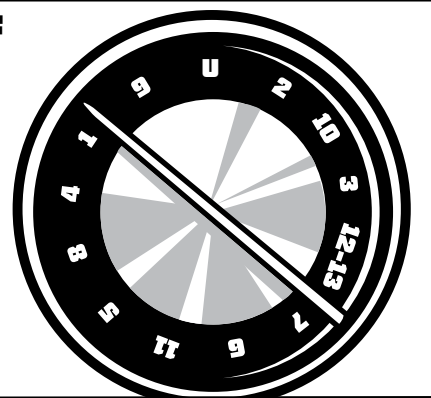

**RECOILTV**

Just as RECOIL magazine made a name for itself giving you the no-holds-barred insight on firearms, we're bringing that same trusted expertise to video. From testing the latest guns, giving in-depth product reviews and expert tutorials, showing you some top-notch vehicles, user-generated content, and lots more, RECOILtv is the premier authority for the content you want and deserve.

WATCH **RECOILTV** AT

**WWW.RECOILWEB.COM**



**RECOILTV**

■ **FULL AUTO FRIDAY**

■ **GUN ROOM**

■ **ROAD TRIPS**

■ **DIY**

■ **TRANSPORT**

■ **TRAINING TUNEUPS**

■ **MAIL CALL**

■ **BALLISTICS**

■ **SHTF/ OFFGRID**

■ **SPONSORED PRODUCT SHOWCASE**

■ **USER GENERATED**

BROUGHT TO YOU BY



SPONSORED BY



**RECOIL**

Just as RECOIL magazine made a name for itself giving you the no-holds-barred insight on firearms, we're bringing that same trusted expertise to video. From testing the latest guns, giving in-depth product reviews and expert tutorials, showing you some top-notch vehicles, user-generated content, and lots more, RECOILtv is the premier authority for the content you want and deserve.



WATCH NOW AT:  
**RECOILWEB.COM**





**RECOIL**  
RECOILWEB.COM

Carnivore is a new publication dedicated to the modern outdoor sportsman with an emphasis on field-to-table hunting and traditions. Every issue focuses on respecting natural food and its origins through features on the latest guns, personality profiles, wild game recipes, and gear reviews.

**CARNIVORE**

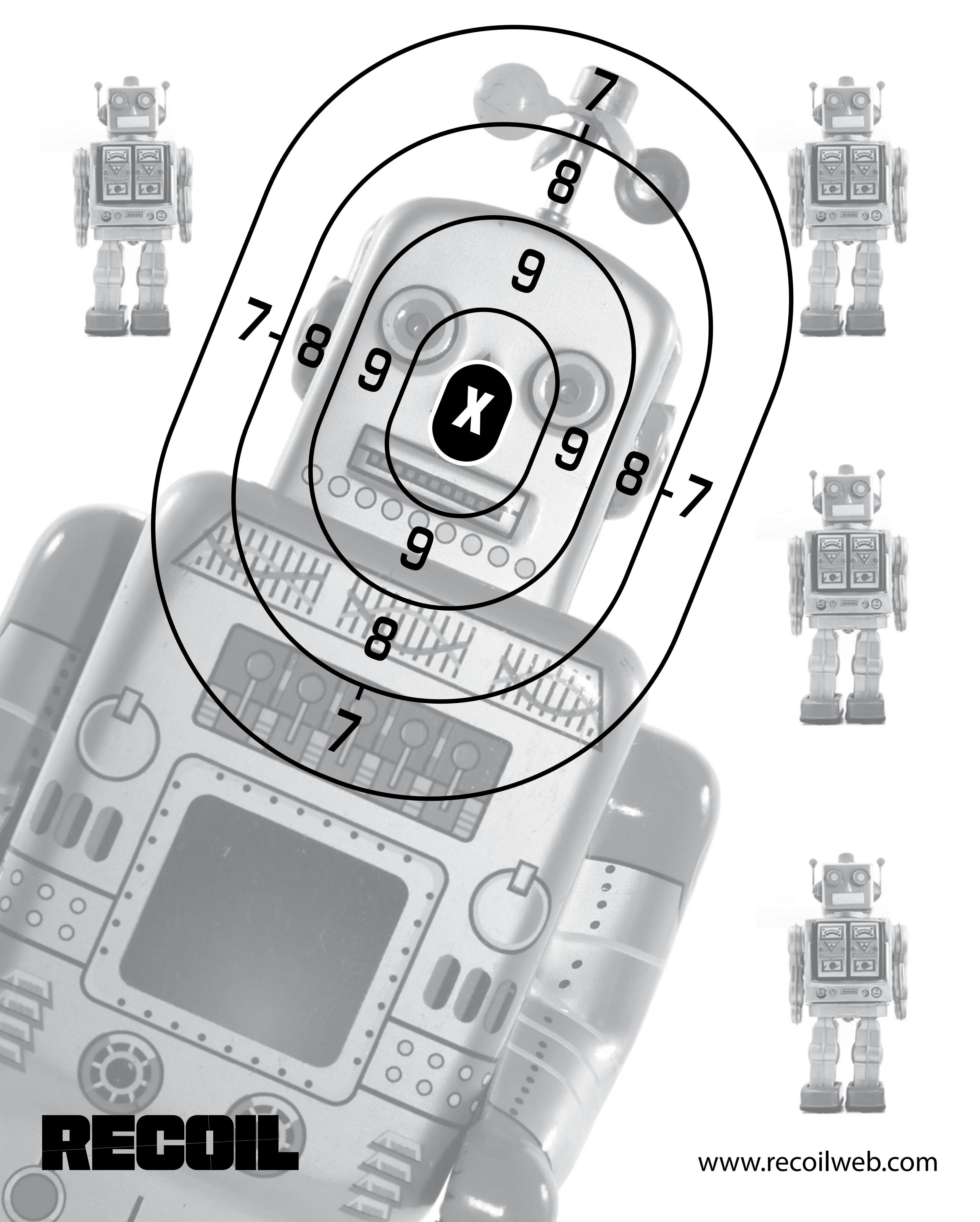

**RECOIL**

[www.recoilweb.com](http://www.recoilweb.com)

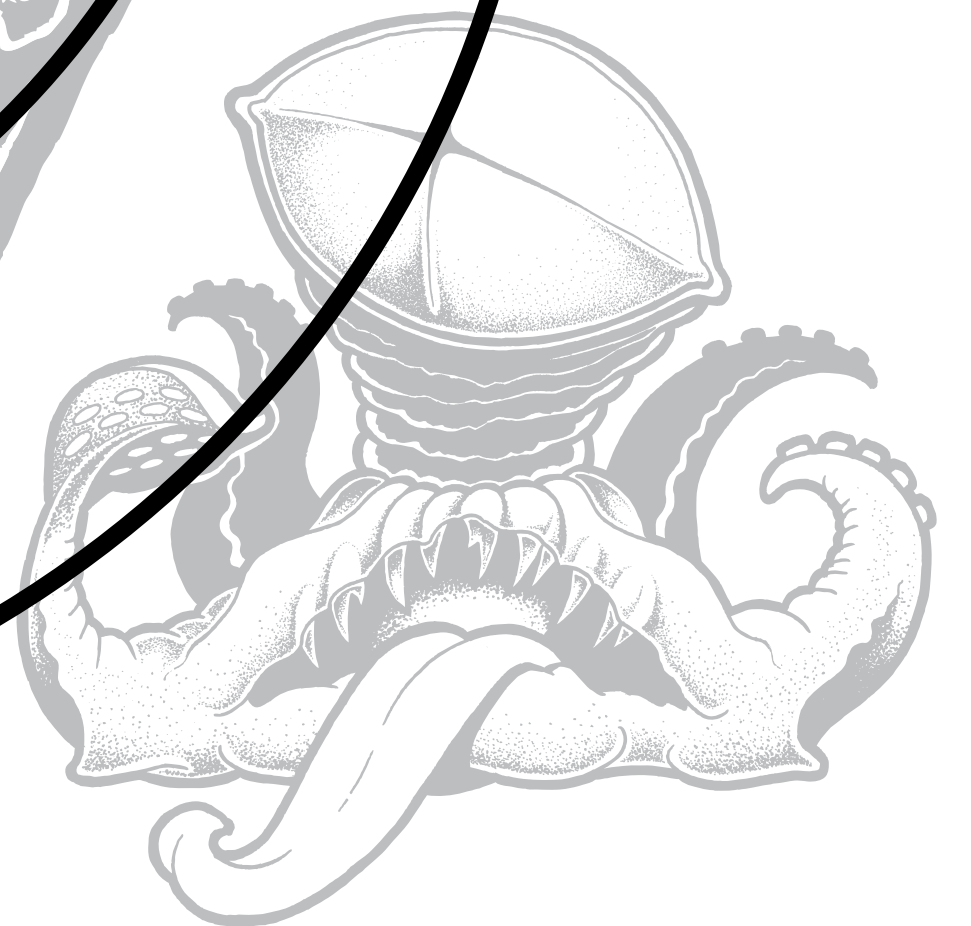
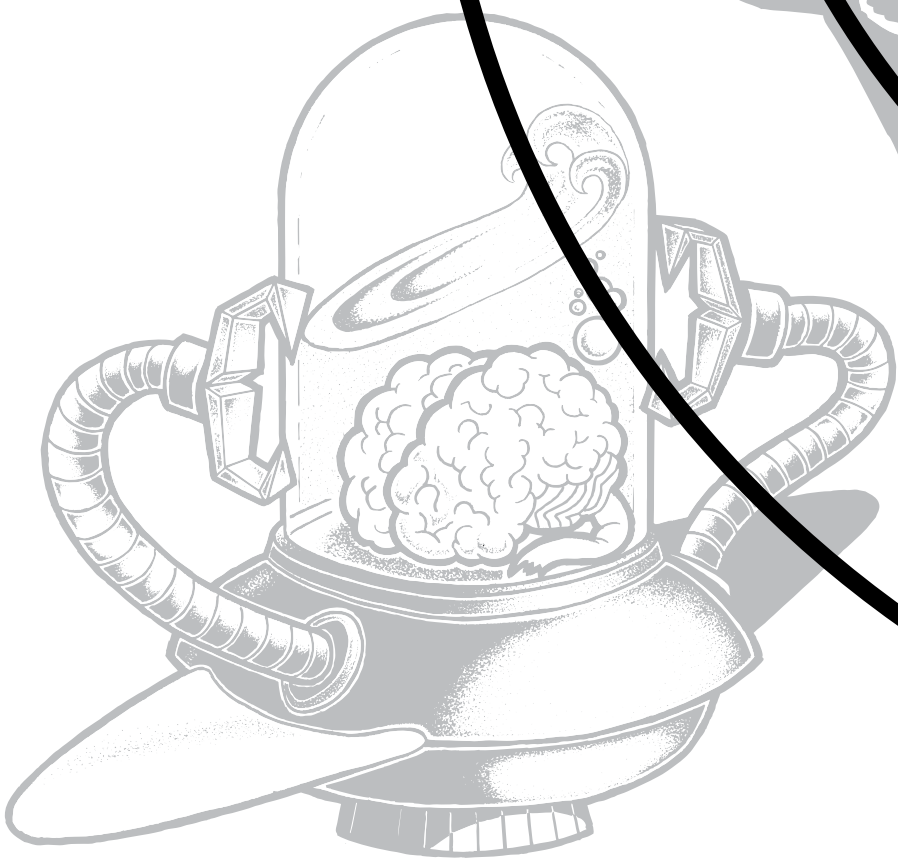
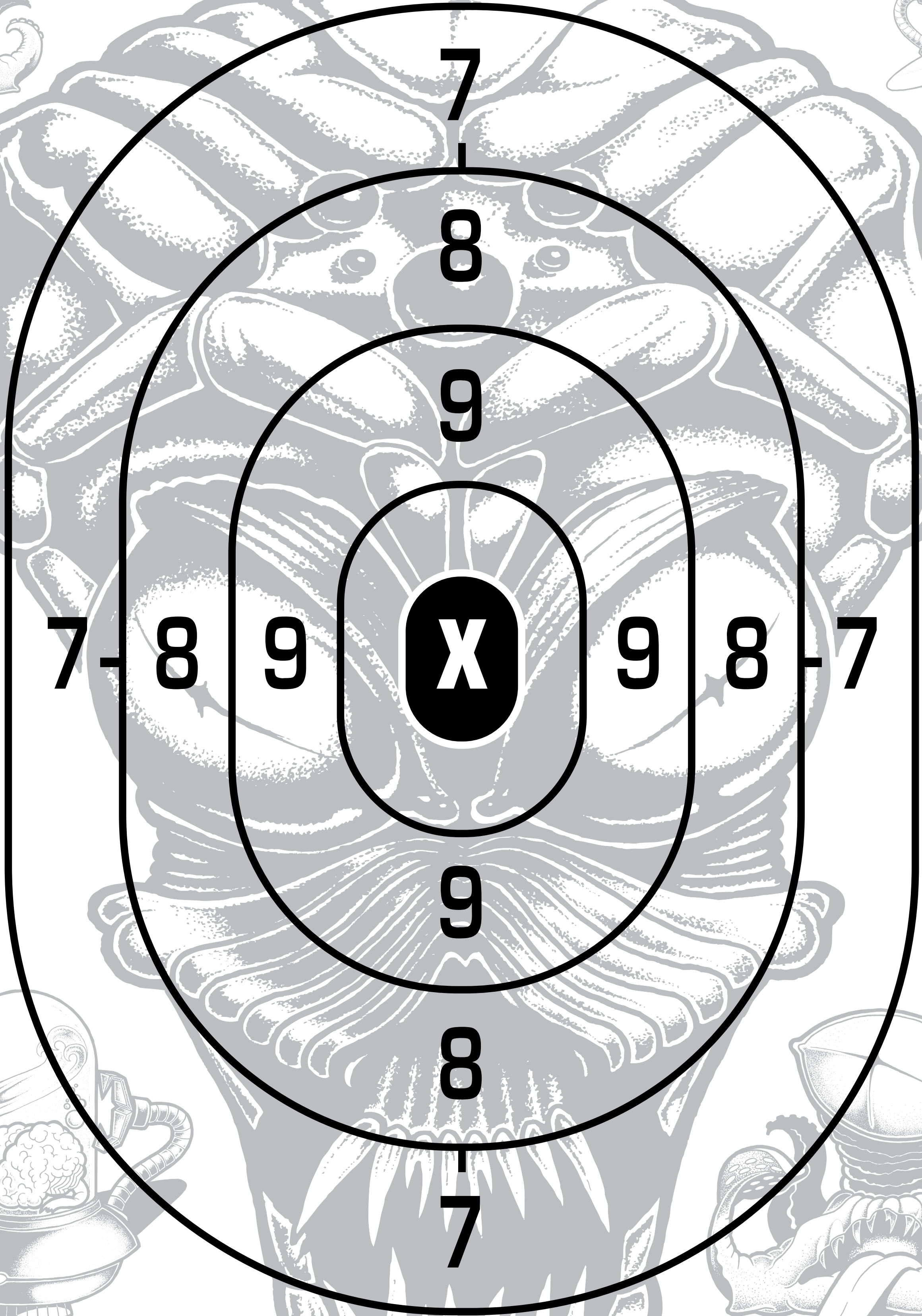
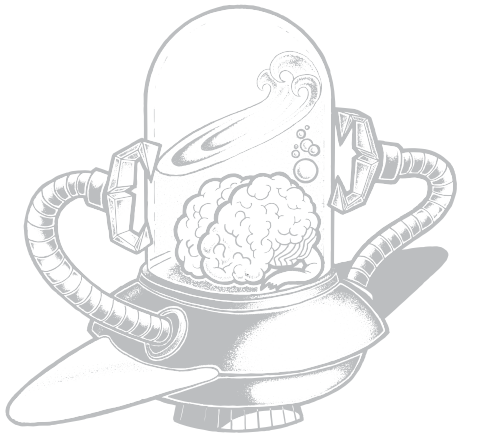

**RECOIL**

[www.recoilweb.com](http://www.recoilweb.com)

## THE OFFSET RIFLE DRILL

The purpose of this drill is to train the operator to account for the sight-line offset from the bore on an AR-15® rifle when engaging targets at close range. This is an important skill because at short range, accuracy of shot placement is critical. The drill is run at five yards to achieve maximum offset in this powerful drill.



## THE COURSE OF FIRE

Distance from target: 5 yards

Firearm condition: Loaded with fifteen rounds

Start position: Down ready

Round count: 15 rounds total

Procedure:

1. On the beep signal, fire 2 rounds into the body in the smaller chest square followed by 1 round to one of the five 2" offset shapes.

2. Repeat this sequence until all five 2" offset shapes have been engaged.

At the end of the course of fire there should be 10 rounds in the smaller chest square, and 1 round in each of the five offset shapes.

Scoring:

7.50 seconds or under = Expert

7.51 - 8.50 seconds = Sharpshooter

8.51 - 10.00 seconds = Marksman

Hits outside the white outline of the smaller chest square or outside the red outlines of the five offset shapes, add 1 second.

Do you have what it takes to pass the class with the Colt Combat Unit™ Offset Rifle Drill? This drill was outlined by Mike Pannone to help you hone critical skills so they're sharp when you need them most.

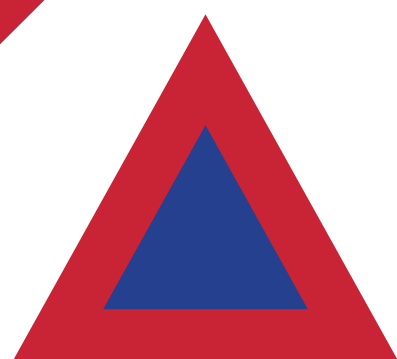

Offset Shape 2

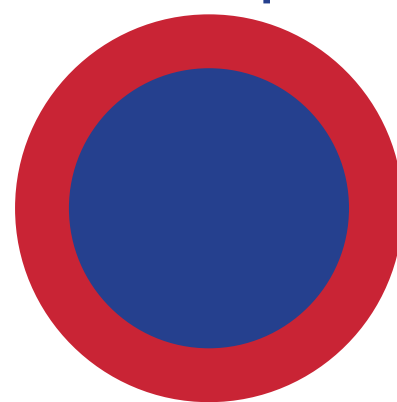

Offset Shape 4

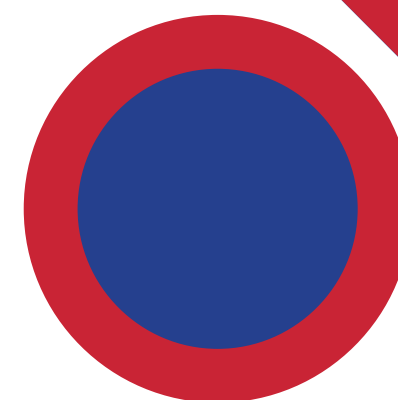
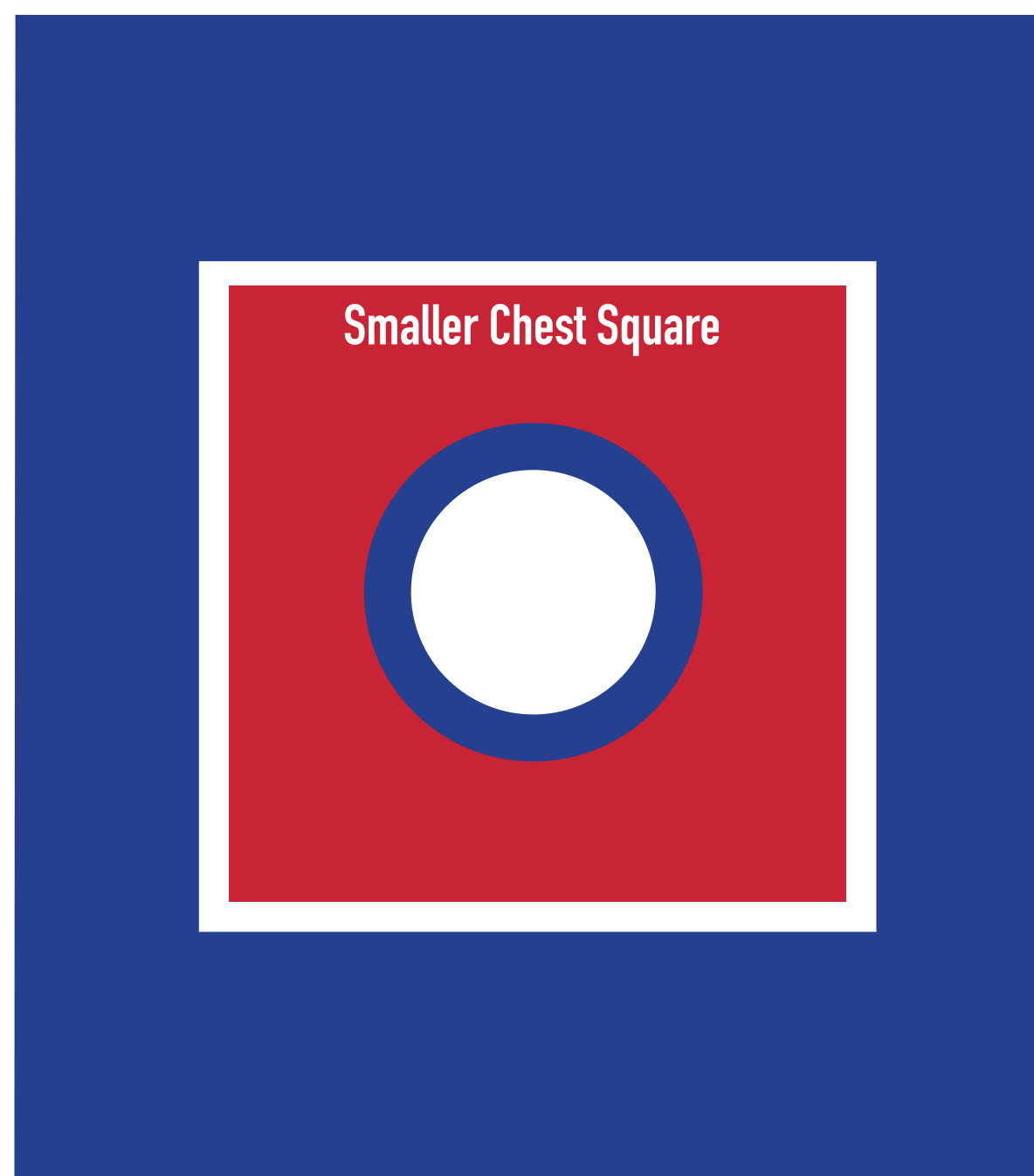

Offset Shape 3



Offset Shape 5

BUILT ONE AT A TIME,™  
PROVEN EVERY ROUND™

# RECOIL

CTT Offset  
SOLUTIONS Rifle Drill  
courtesy of Mike Pannone of Colt Combat Unit™



## THE BFM DRILL

Bill Drill, Fast Drill, Mozambique Drill

This target was designed using the harder-scoring areas of both the IDPA target and the USPSA target, combining them both into a more difficult, productive training target.

The BFM Drill is designed to combine the benefits of three standard training drills that you may be familiar with, to offer a well-rounded cross-training exercise. This drill combines all of the techniques you need to practice to excel at both competitive and defensive shooting.

Hits in the blue field outside the target, add 3 seconds.

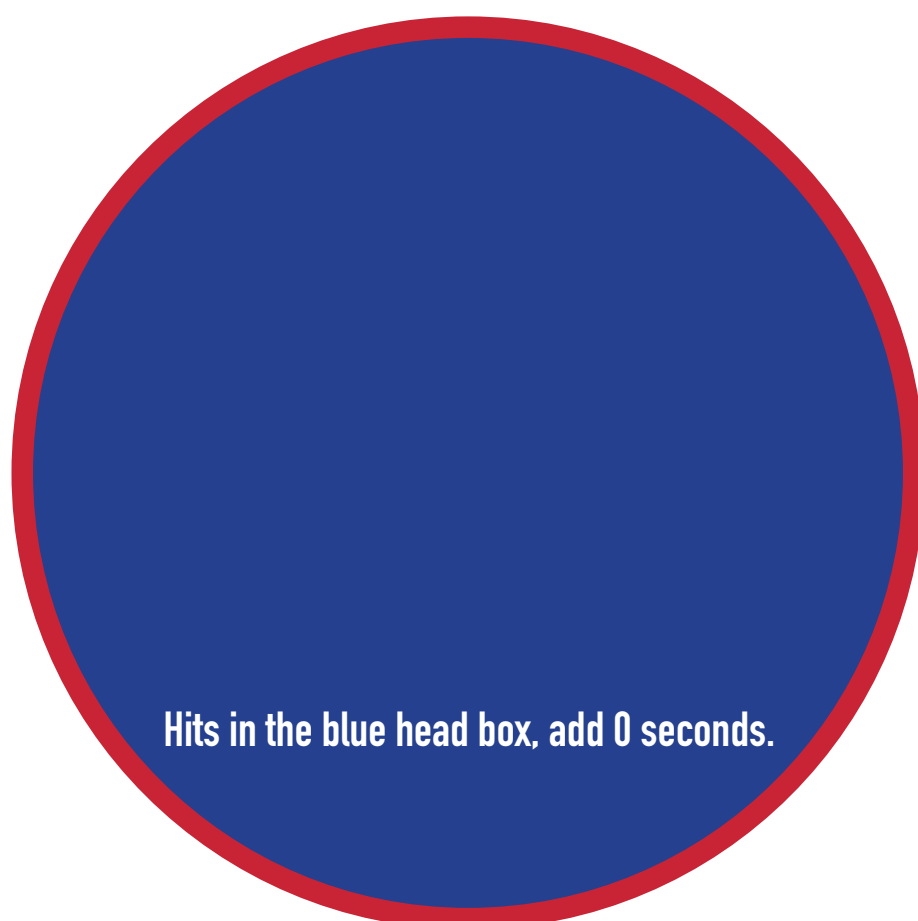

Hits in the blue head box, add 0 seconds.

## TEAM COLT

### HANDGUN CROSS-TRAINING DRILL

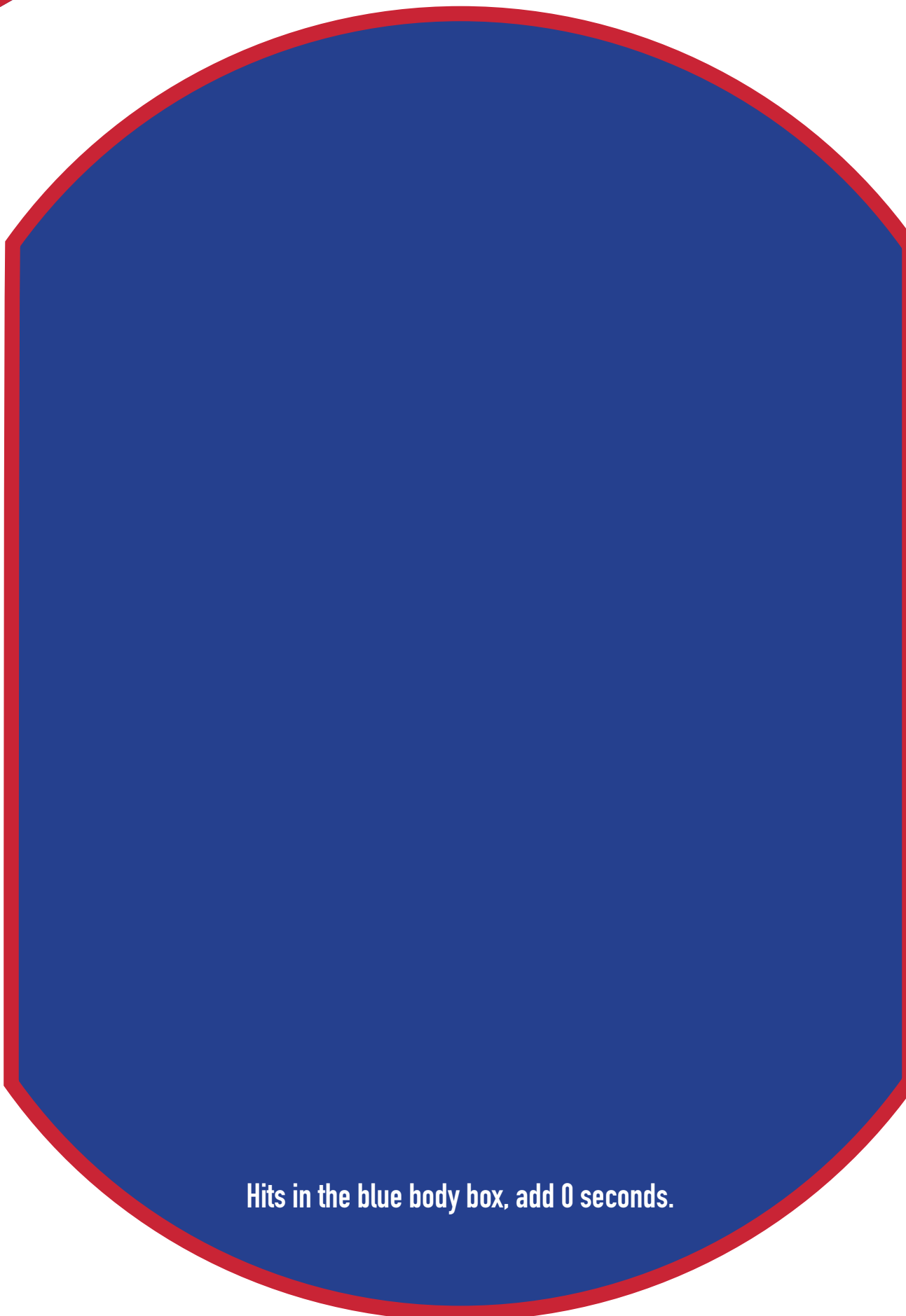

Hits in the blue body box, add 0 seconds.

Hits in the white or red of the target body, add 1 second.

## THE COURSE OF FIRE

Distance from target: 7 yards

Firearm condition: Loaded with eight rounds

Start position: Handgun holstered, hands relaxed at sides

Round count: 15 rounds total

Procedure:

1. On the beep signal, draw and engage the target with 6 rounds to the body box.
2. Engage the head box with 2 rounds, then perform an emergency slide lock reload.
3. Engage the body box again with 4 rounds.
4. Transition to the head box and fire 1 round.
5. Transition back to the body box and fire 2 rounds.

Scoring:

10.00 second or under	=	A rating
10.01 - 13.00 seconds	=	B rating
13.01 - 16.00 seconds	=	C rating
16.01 - 20.00 seconds	=	D rating
20.01 seconds and over	=	Fail

Hits outside the blue of the designated head or body box, but still in the red or white body of the target, add 1 second. For all rounds outside the body, add 3 seconds.

Hits in the blue field outside the target, add 3 seconds.

Do you have what it takes to pass the class with the Team Colt Handgun Cross-Training Drill? This drill was outlined by Team Colt Sponsored Shooter Mark Redl to help you hone critical skills so they're sharp when you need them most.

BUILT ONE AT A TIME,  
PROVEN EVERY ROUND™

RECOIL



# CP33™ THE GAME

HIT THE™ FOR AN INSTANT WIN

The first to get to 33 in the fewest shots, wins.

The target diagram consists of a central circle with the number '1'. Surrounding it are four circles with the number '3' and four circles with the number '2'. The outermost ring consists of sixteen circles, each containing the number '10', arranged in two vertical columns of eight on each side of the central area.

**RECOIL**

[KelTecWeapons.com](http://KelTecWeapons.com)

INNOVATION. PERFORMANCE. **KEL  
TEC**

# RECOILWEB



**RECOIL**

Looking for the latest news and product releases in the gun industry? Stay up to date by signing up for the Recoil Newsletter by visiting [www.recoilweb.com/newsletter-signup](http://www.recoilweb.com/newsletter-signup). This weekly newsletter is packed with information on new issue releases, RECOILtv videos, and current events in the firearms world. For more web-exclusive content, head to Recoilweb.com, like our page at [www.facebook.com/Recoil.gun.lifestyle](https://www.facebook.com/Recoil.gun.lifestyle), or follow us on Instagram at [@recoilmagazine](https://www.instagram.com/recoilmagazine).

SIGN UP NOW AT:  
**RECOILWEB.COM**

# SHOOTIN GALLERY

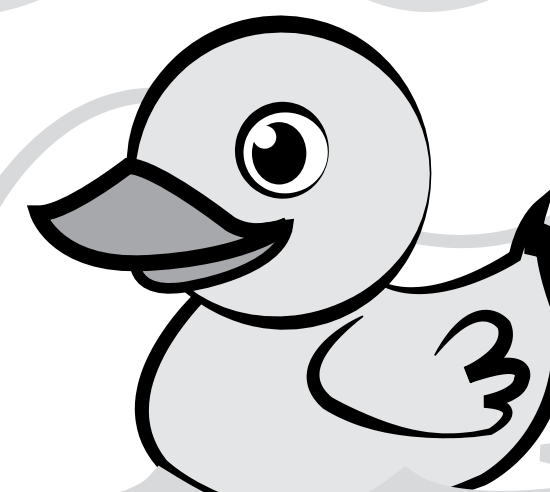
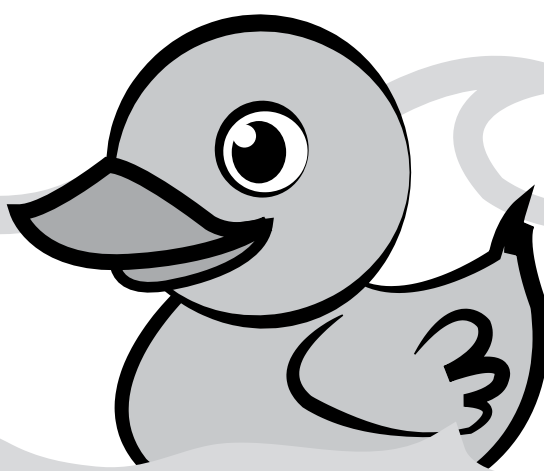
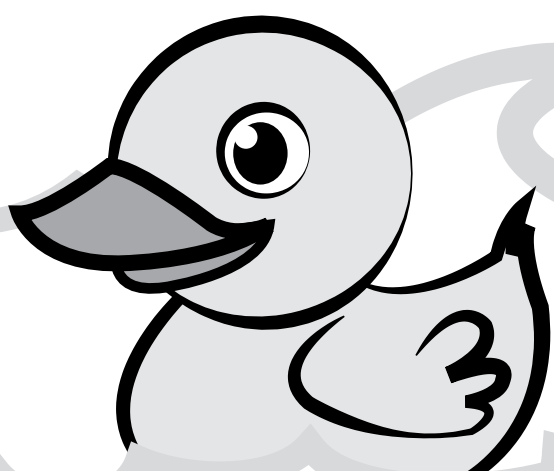
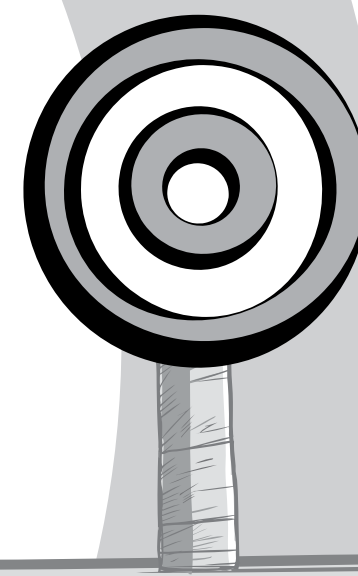
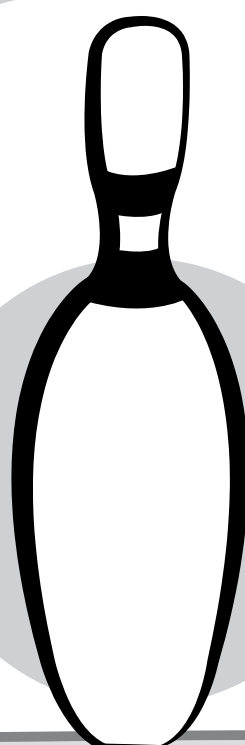
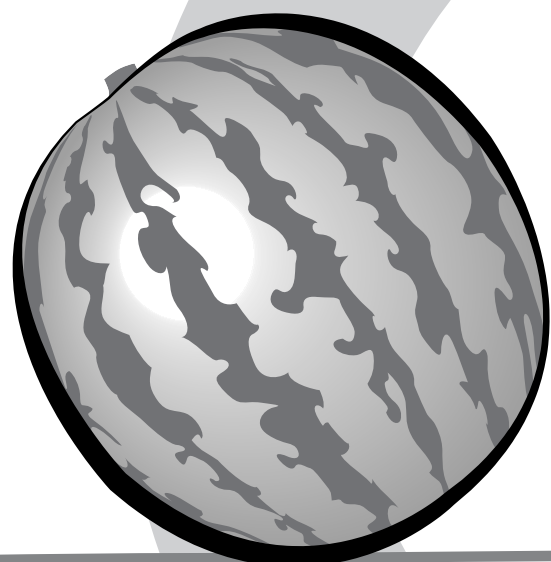
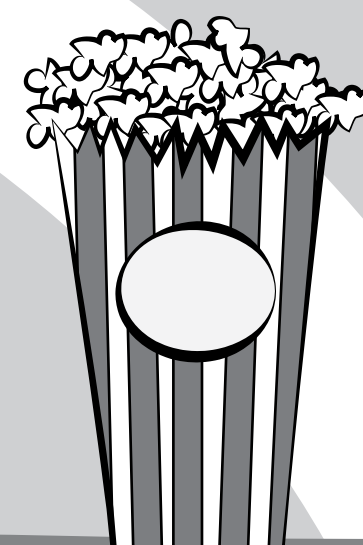
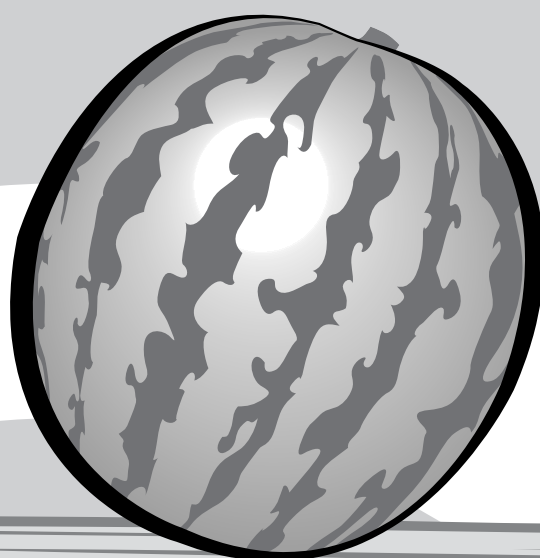
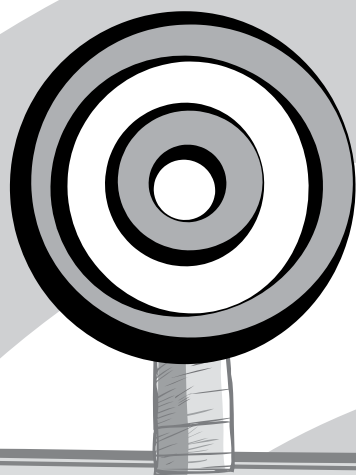
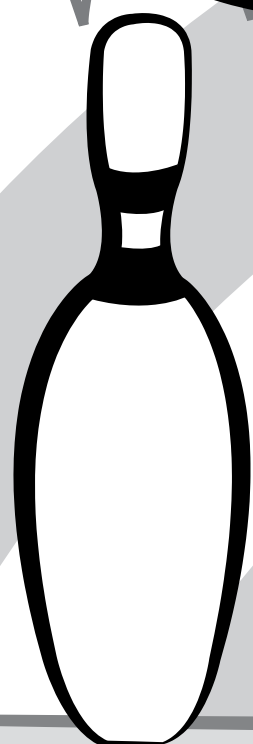

**RECOIL**

danieldefense.com  
**DANIEL DEFENSE**  
» LIGHTER, STRONGER, BETTER...®





# Dom Raso's DANIEL DEFENSE MK-12 DRILL

\*ALL SHOTS STANDING ARE TO CHEST BOX  
\*ALL SHOTS PRONE ARE TO HEAD BOX

## DYNAMIC

- 5 shots standing at 100 Yards
- 5 shots Prone
- Sprint to 50 Yard line w/mag change
- 5 shots standing
- 5 shots prone
- 1 more shot in prone
- SCAN, END

## STATIONARY (Limited Range)

- 5 shots (chest)
- 5 shots (head)
- 5 shots (chest)
- 5 shots (head)
- 1 shot (head)
- SCAN, END

# DANIEL DEFENSE

DANIELDEFENSE.COM PROUDLY AND EXCLUSIVELY MADE IN THE USA FIND US ON   

## GEAR REQUIRED:

- 1 mag in the gun
- 4 extra mags (preferably in a carrier)
- All mags loaded with 5 rounds
- Optic of your choice

## SCORE:

DRILL TIME:

TOTAL MISSES:  +  x 10 sec.

FINAL TIME:

# RECOIL

Watch Dom shoot the drill, and then try to beat his time:



<http://youtu.be/fPFUWOYkrDE>

Find and follow Dom on Instagram at  **Domraso** and on Twitter and Facebook at  **Domrasojr**

Visit [dynamisalliance.com](http://dynamisalliance.com)

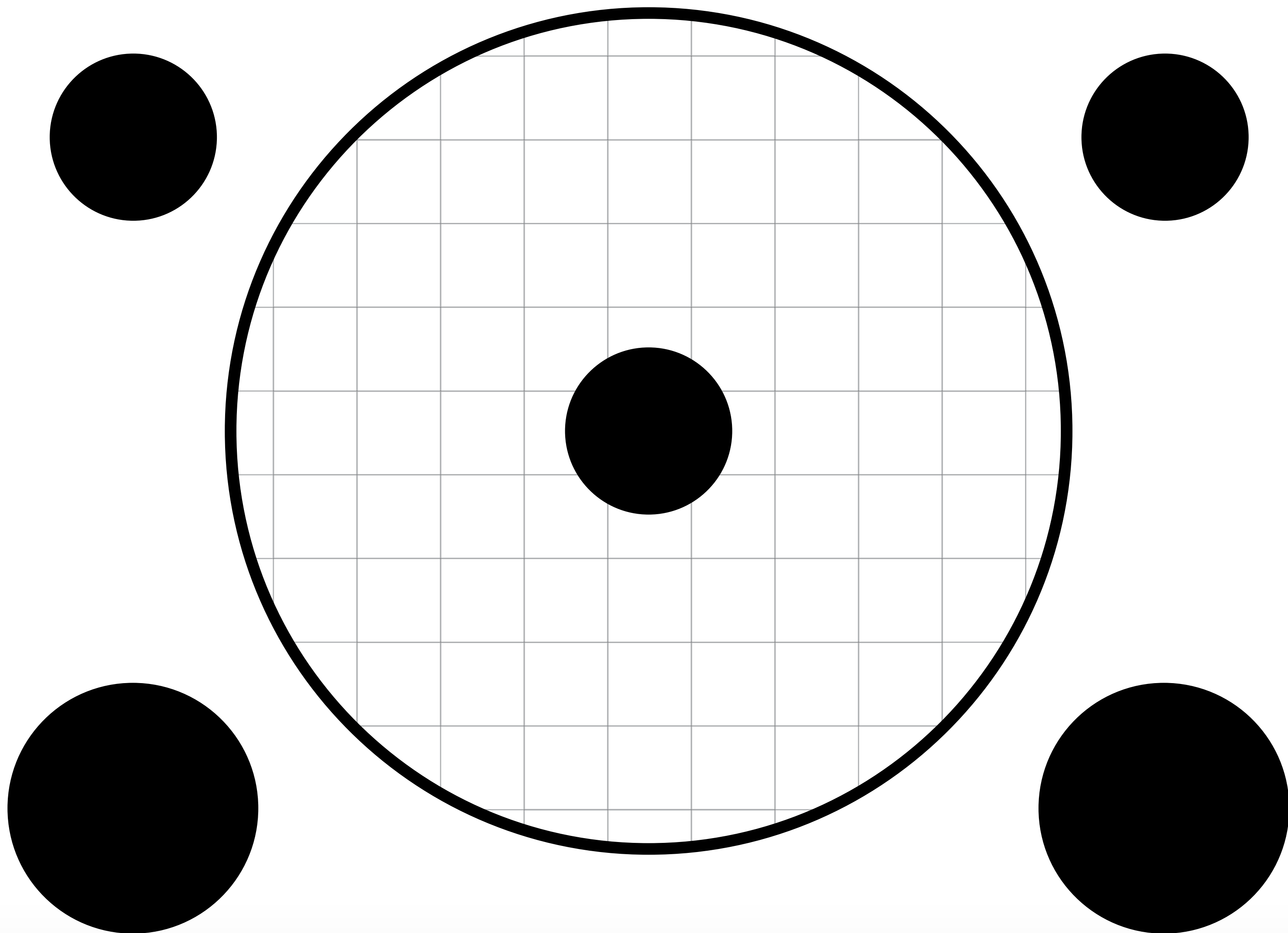
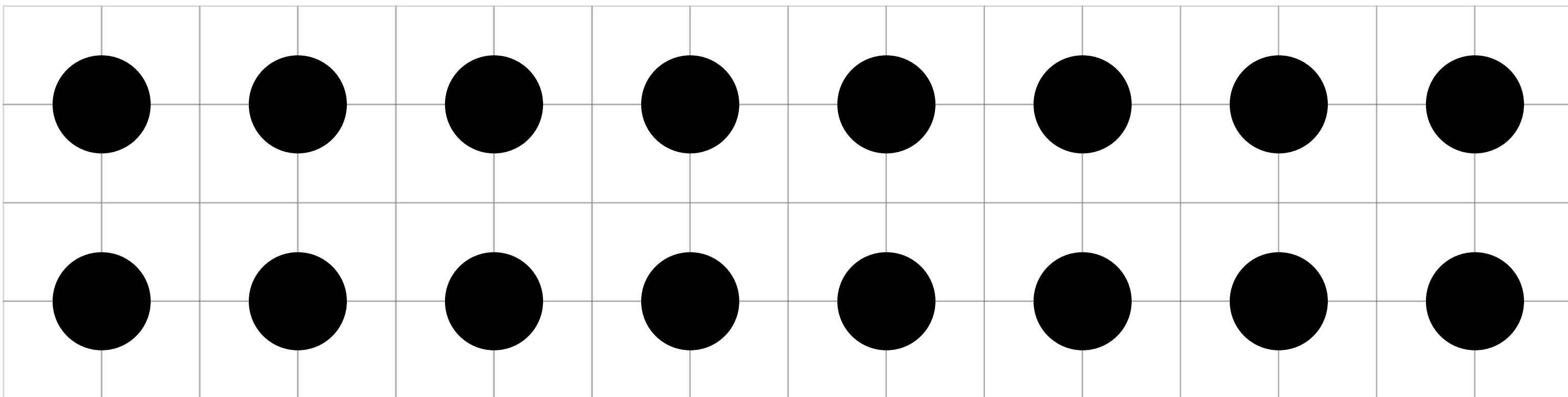

**CET ZERO DATA**

ZERO AT 50M FOR RED DOT. MOVE BACK TO 100, HOLD CENTER THEN CONFIRM, MOVE BACK TO 200, HOLD CENTER THEN CONFIRM, MOVE BACK TO 300, HOLD CENTER THEN CONFIRM. FIND THE CENTER OF YOUR GROUP AND DRAW A LINE OUT TO THE SIDE TO FIND THE STORY OF YOUR BULLET. ADJUST THE 50M UP OR DOWN TO BRING YOUR 300 UP OR DOWN.

50 METERS = 55 YARDS | 100 METERS = 109 YARDS

**50 YARD ZERO HOLD OVERS**

0-100= HOLD CENTER  
 200= HOLD CENTER  
 300= HOLD CENTER - HEAD  
 400= HOLD JUST ABOVE HEAD  
 500= HOLD HALF BODY ABOVE HEAD

**BACK-UP IRON SIGHTS**

WINDAGE: 1 CLICK  
 100 YD : 1 CLICK = 1/2"  
 50 YD : 1 CLICK = 1/4"  
 FRONT SIGHT ELEVATION  
 100 YD : 1 CLICK = 1"  
 50 YD : 1 CLICK = 3/4"  
 REAR ELEVATION  
 100 YD : 1 CLICK = 3/4"  
 50 YD : 1 CLICK = 1/2"

**AIMPOINT - EOTECH**

25 YD : 1 CLICK=1/8"  
 50 YD : 1 CLICK=1/4"  
 100 YD : 1 CLICK=1/2"  
 200 YD : 1 CLICK=1"  
 300 YD : 1 CLICK=1.5"

**VORTEX SPARC**

25 YD : 1CLICK=1/4"  
 50 YD : 1CLICK=1/2"  
 100 YD : 1 CLICK=1"  
 200 YD : 1 CLICK=2"  
 300 YD : 1 CLICK=3"

**TRIJICON**

100 YD : 1x OPTICS : 1 CLICK= 1"  
 100 YD : 1.5X OPTICS : 2 CLICKS = 1"  
 100 YD : 2X OPTICS : 2 CLICKS = 1"  
 100 YD : 3X OPTICS : 4 CLICKS = 1"  
 100 YD : 4X OPTICS : 2 CLICKS = 1"

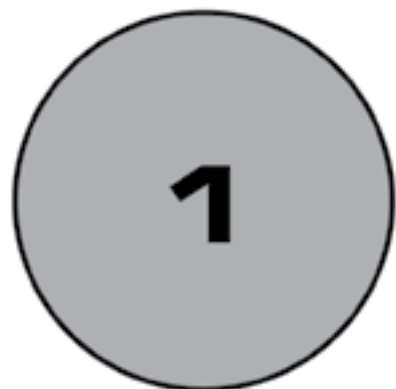

1

2" circle



4



0

2.5"x1.5" square

-1



2

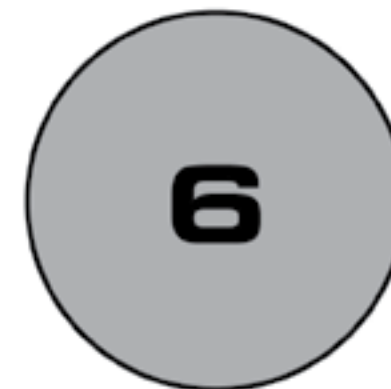

6

2" circle



3



**Drill 1 - Think, Think, Think**  
(from low ready at 5yds.)

Add 2s for every miss.  
Lowest overall score wins.

Intermediate

On the buzzer engage circles with 1 round each in numerical order 1-6.

Advanced

Load 3 mags with 4 rounds each.

On the buzzer engage circles with 1 round each in numerical order of 1-6 then 6-1.  
Slide lock reload as needed.

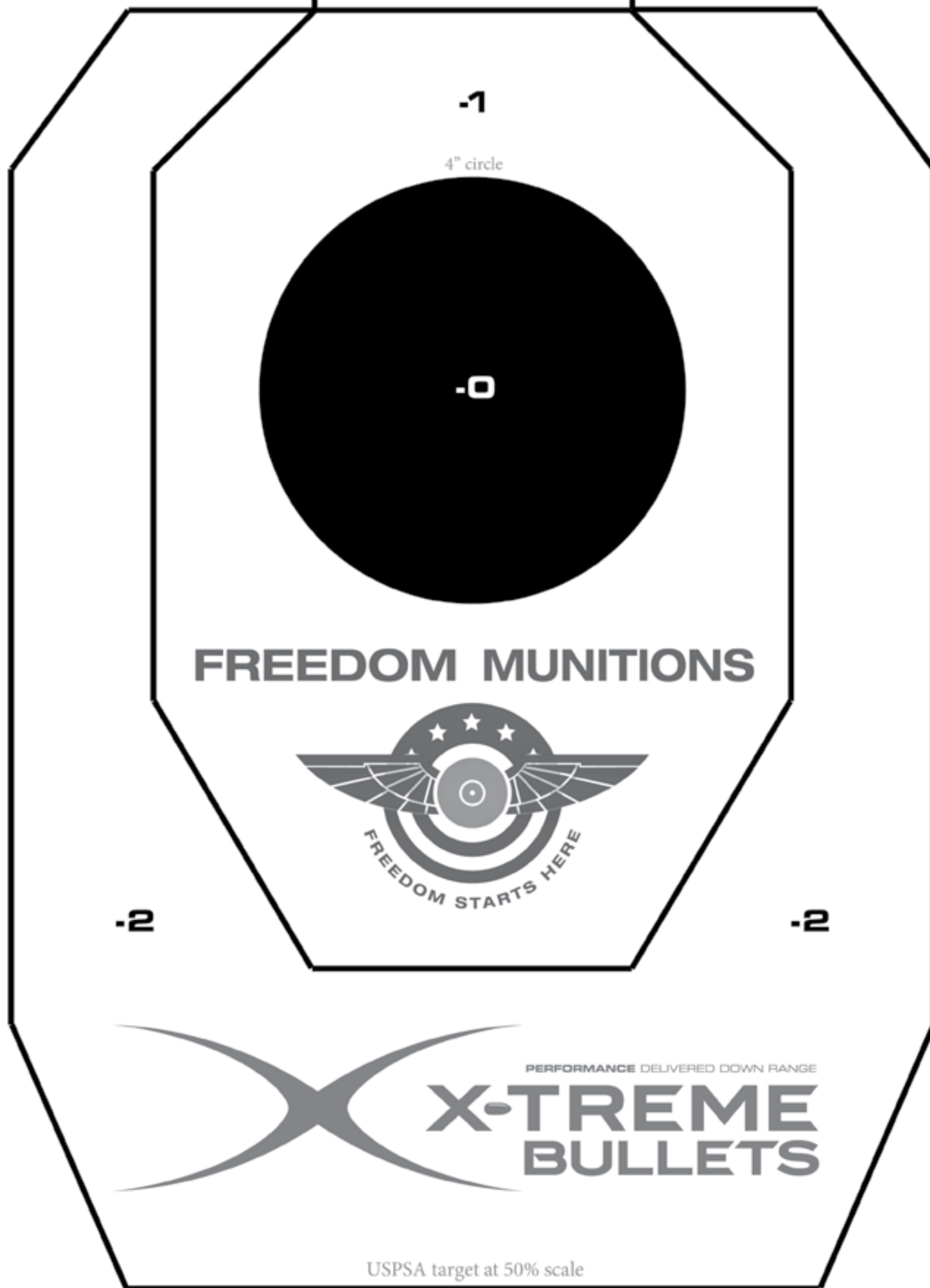

FREEDOM MUNITIONS



USPSA target at 50% scale



**Drill 3 - F.A.S.T.**  
*Fundamentals, Accuracy, & Speed Test*  
(courtesy of pistol-training.com)

Distance: 3.5yds  
(due to 50% reduced target size)

Start from a concealed holster with exactly 2 rounds loaded.

On the buzzer:

1. draw
2. fire 2 rounds at 3x5" box
3. perform a slide lock reload
4. fire 4 rounds at the 8" circle

Misses to the 3x5" box add 2sec.  
Misses to the 8" circle add 1sec.

**Total Time (raw + misses):**  
10secs+ : Novice  
less than 10secs : Intermediate  
less than 7secs : Advanced  
less than 5secs : Expert



**Drill 2 - Count 'Em All**  
(from low ready at 5yds.)

Add 2s for every miss or incorrect number of shots.  
Lowest overall score wins.

Intermediate

On the buzzer engage targets with one round each in numerical order 1-6.

Advanced

On the buzzer engage targets with the number of rounds each shape indicates, in clockwise order starting with 1.

Slide lock reload as needed.  
Load mags to 10rds for added difficulty.

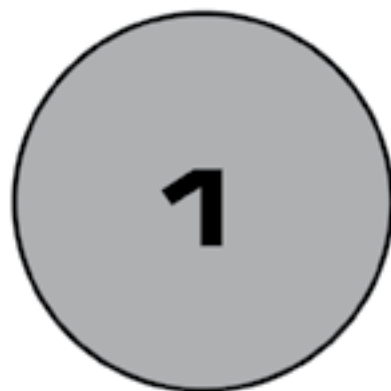

1



2

1" square

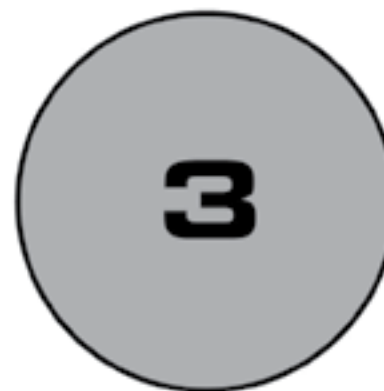

3

2" circle



4



5



6

Share your target & time results on Instagram:

@freedommunitions

@recoilmagazine

Hashtag: #recoiltarget

FREEDOM MUNITIONS



RECOIL



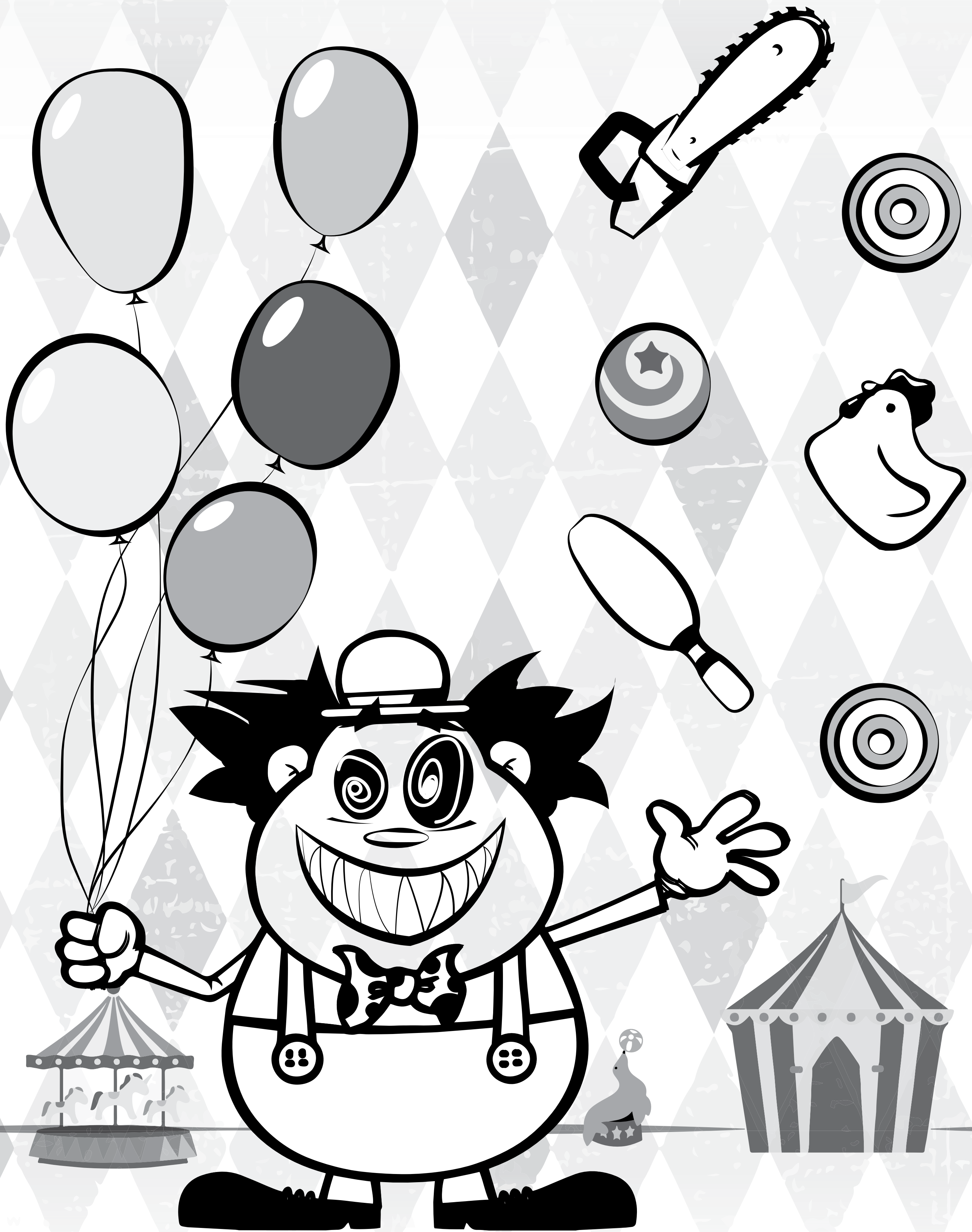

**RECOIL**

**WWW.RECOILWEB.COM**



**RECOIL**

**Erathr3**  
Apparel & Hardgoods for the Independent  
[www.erathr3.com](http://www.erathr3.com)

WHAT ALL GUNS SHOULD BE™



**SHOW US HOW YOU DID!**

TAKE A PHOTO OF YOUR  
TARGET AND USE THE  
#KIMBERTARGET TO  
SHARE WITH US.



**RECOIL**



[aguilaammo.com](http://aguilaammo.com)

**RECOIL**



Right  
Down

## 25M Target

## 100M Target

Left  
Down

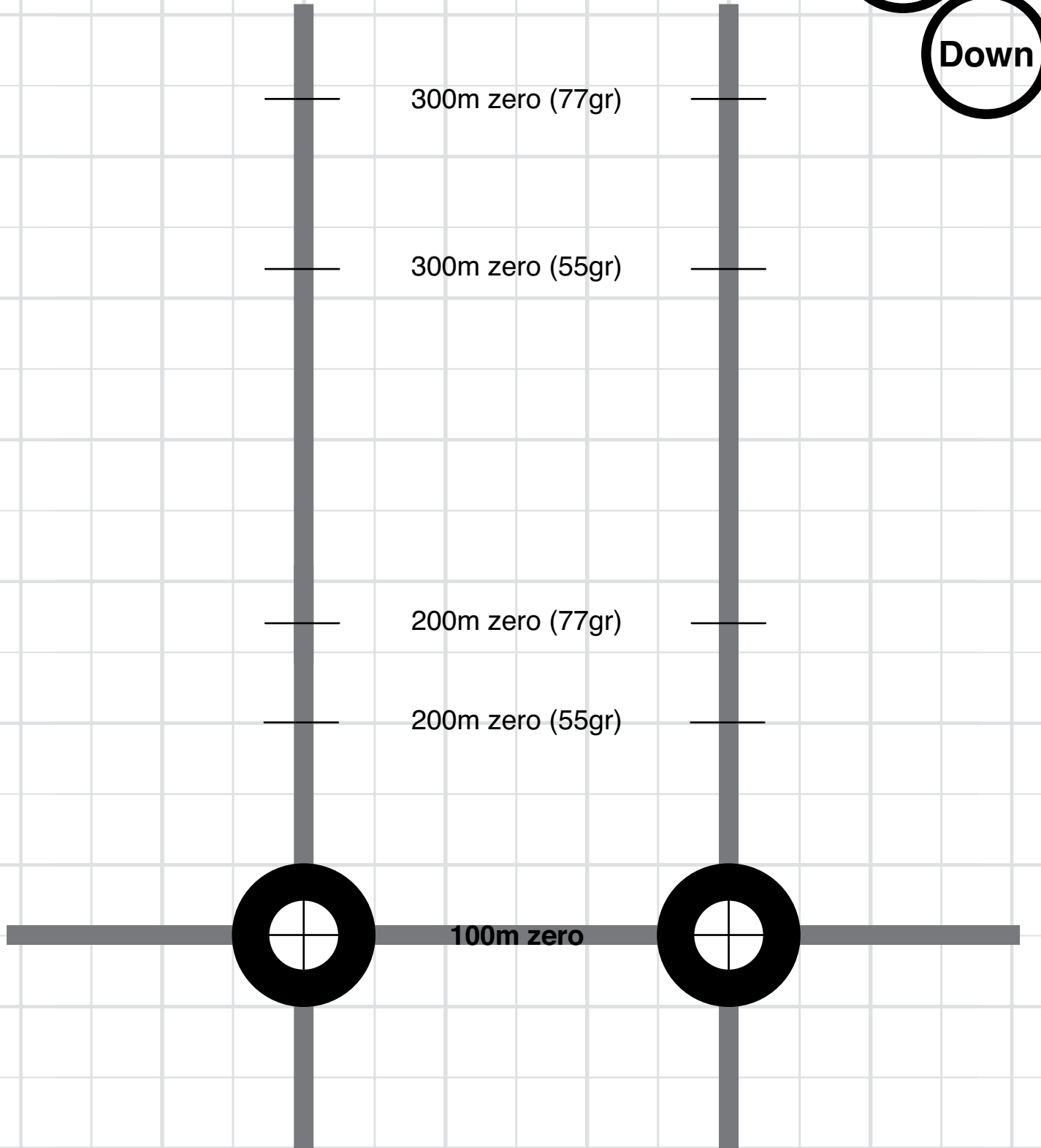
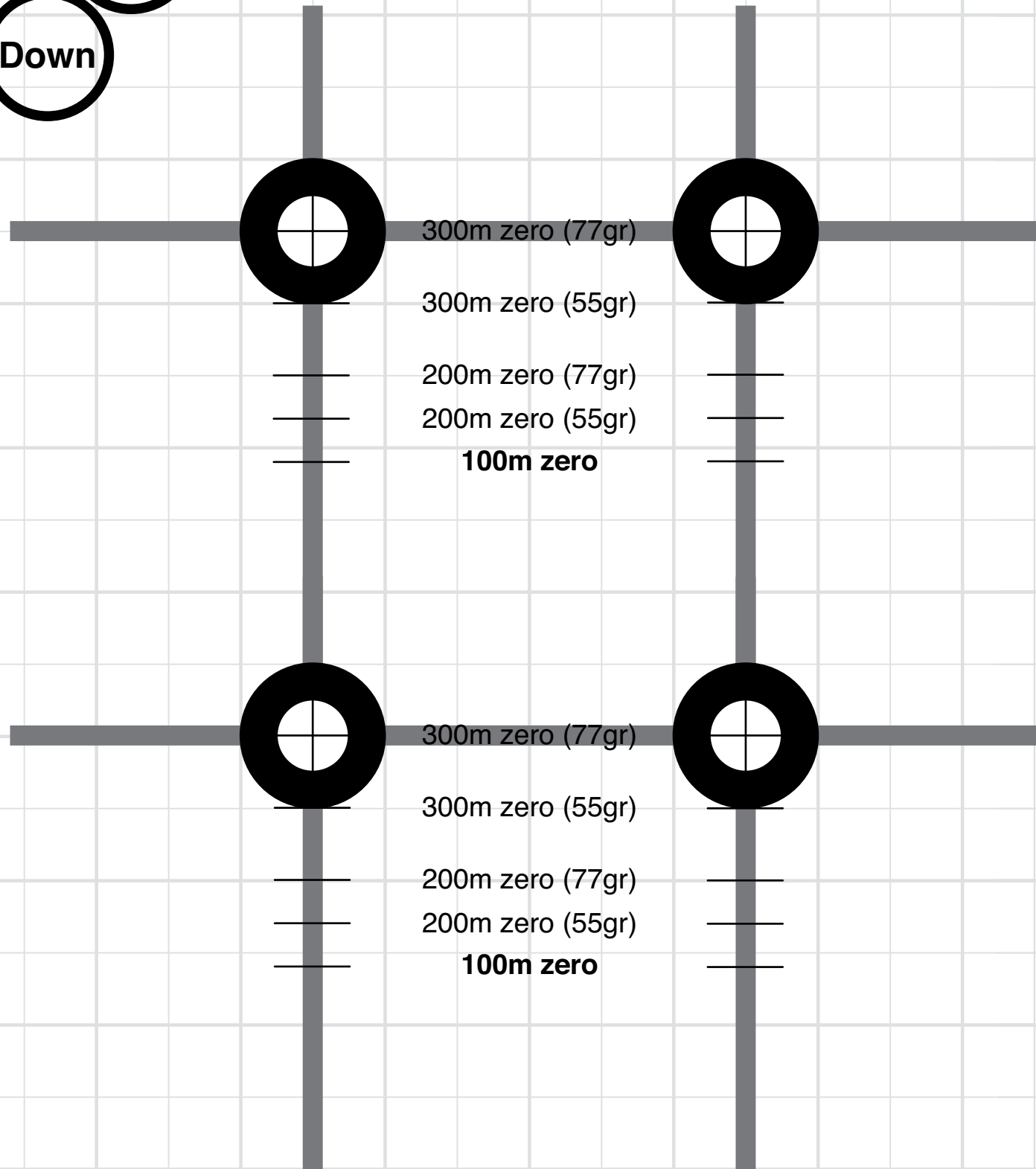

## 50M Target

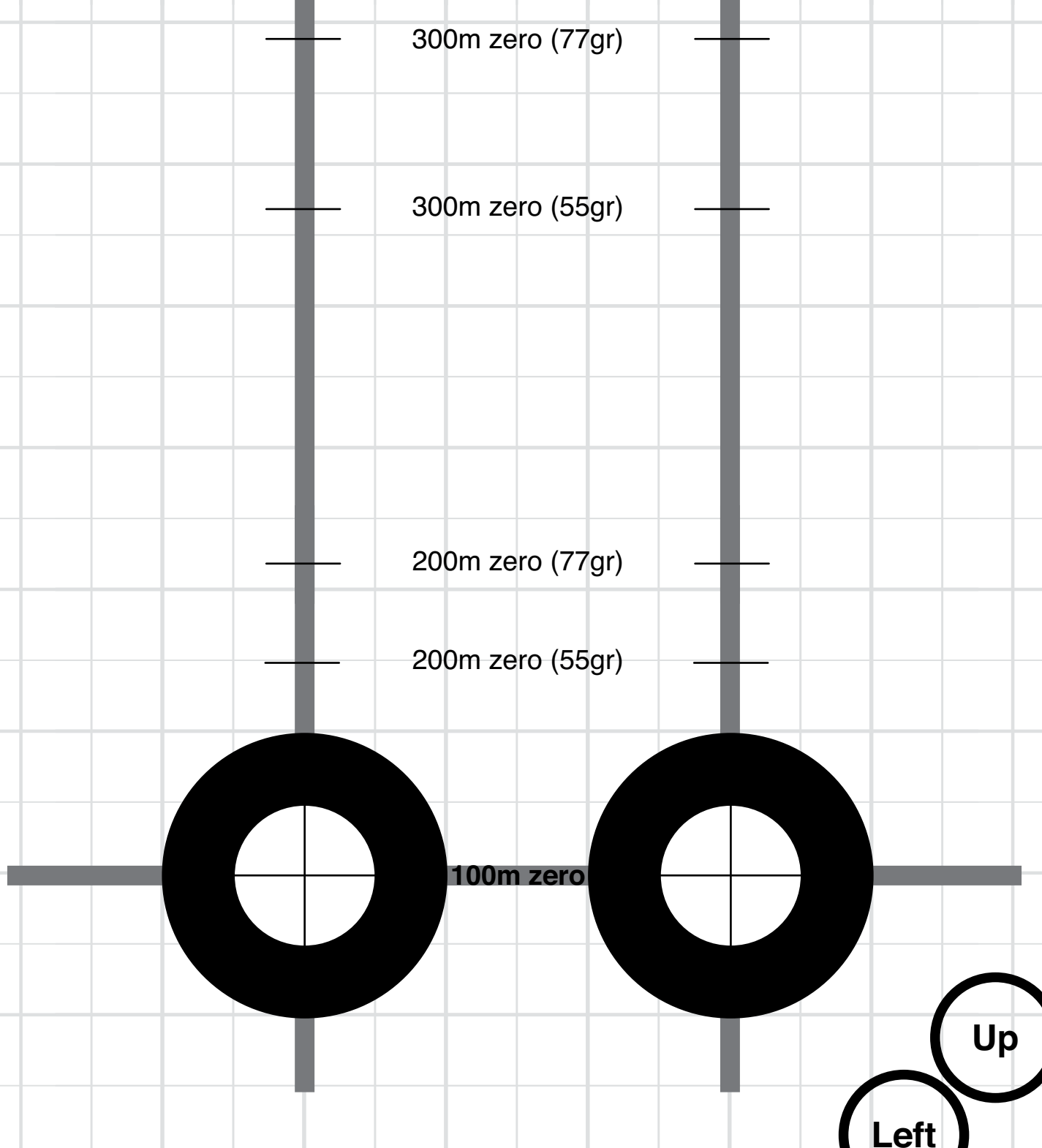
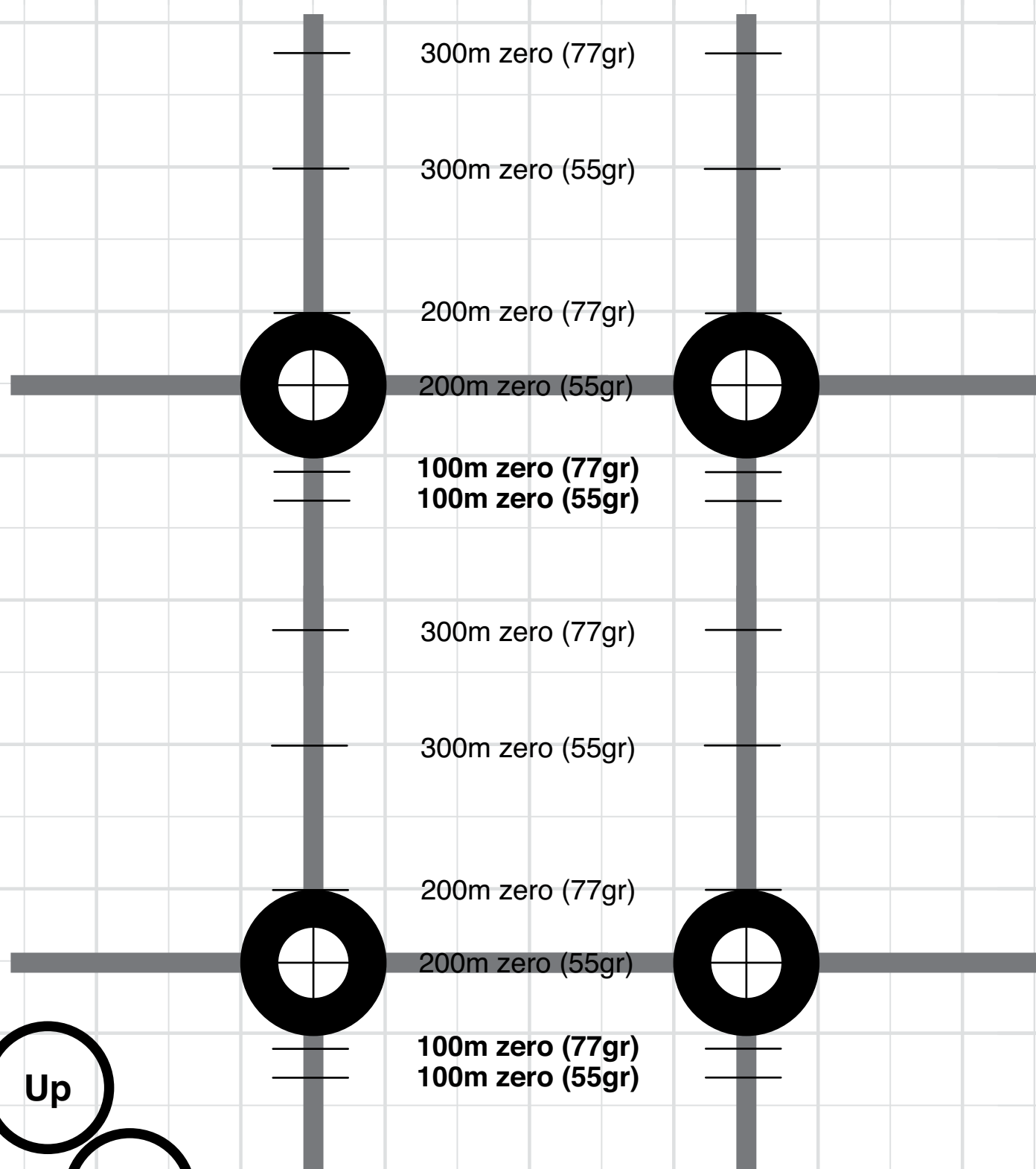

Up  
Right

Up  
Left

### NOTES:

- This target is designed for you to use at 25, 50 and 100 meter ranges, to sight in for a 100, 200, or 300 meter zero. Aim at the bullseye, but adjust your optic to dial bullet impacts to the marked offset for your desired zero.
- The marked offsets are calibrated to match the Trijicon VCOG with M193 (55gr) and Mk262 (77gr), but should get you close with other weapon/optic/ammo combinations. Note the Trijicon VCOG is intended to be zeroed at 100 meters.
- Actual trajectories will vary based on your specific weapon, ammunition and environmental conditions. Please be sure to verify your zero at your actual desired range.
- For more info and details on how to use this target: [www.recoilweb.com/trijicontarget](http://www.recoilweb.com/trijicontarget)

# RECOIL



Brilliant Aiming Solutions™

[www.trijicon.com](http://www.trijicon.com)





**RECOIL**

**DANIEL  
DEFENSE**

» LIGHTER, STRONGER, BETTER...  
» DANIELDEFENSE.COM » 866.554.GUNS

» DEFENDING YOUR NATION, DEFENDING YOUR HOME.™

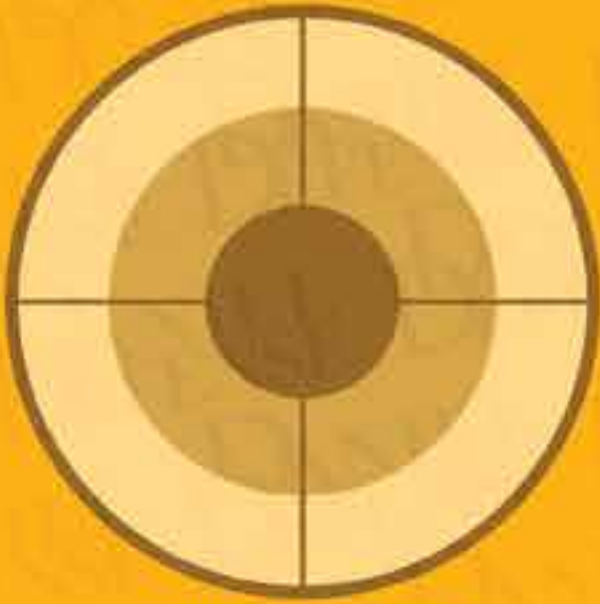

CONFIRM PISTOL ZERO



CONFIRM RIFLE ZERO

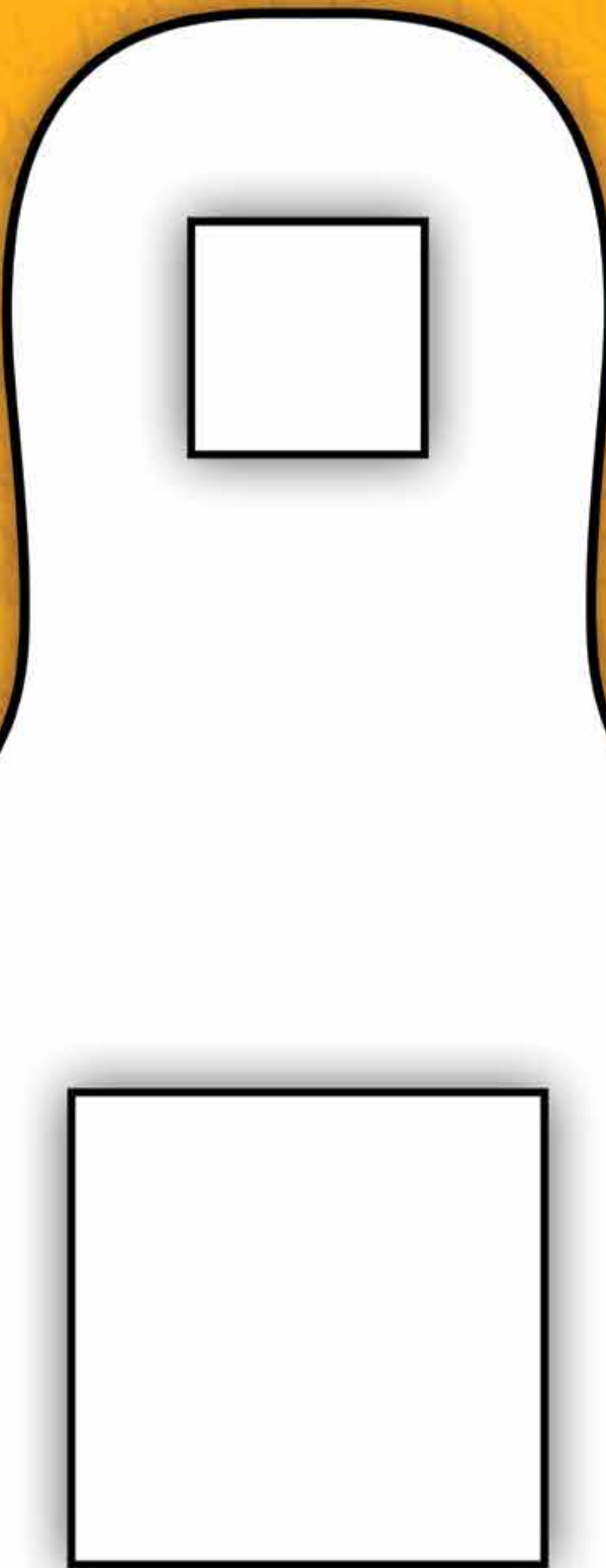

### Dom Raso's CQB HIGH LOW DRILL

- WEAPONS** Daniel Defense DDM4V5  
Sig Sauer 226 Tac Ops with VZ Grips
- TARGET** Silhouette at 5 yards  
2" square on head (*in front of the Pons Medulla*)  
4" square on chest (*in front of heart/chest plate*)
- CONDITION** High Ready (Weapon Slung)  
Carbine: 1 round in the chamber and 3 in the mag  
Pistol: 1 round in the chamber and a full mag  
(*Holster used was Sorpa with retention*)
- ON BUZZER** **WITH CARBINE:**  
1 shot to the head  
2 shots to the body  
1 shot to the head (gun goes dry)
- TRANSITION TO PISTOL:**  
2 shots to the body  
1 shot to the head  
(scan for targets)
- END DRILL**  
Goal time: 6.00, Time to beat 4.85
- POINTS OF PERFORMANCE**  
1. Working your high ready  
2. Pushing out and hitting your first round accurately  
3. Changing levels with your shots with both primary & secondary  
4. Transition to your secondary in the middle of the drill  
5. Balancing accuracy and speed

Watch Dom shoot the drill at  
<http://youtu.be/uJQa95PPjQE>



Find and follow Dom at  
**Domrasojr**  
on Twitter and Facebook!

**RECOIL**

**DANIEL  
DEFENSE**  
» DANIELDEFENSE.COM » 866.554.GUNS



**Post  
your  
target  
results  
on our  
facebook  
page!**

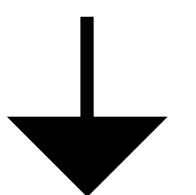

**RECOIL**

[www.midwestindustriesinc.com](http://www.midwestindustriesinc.com)

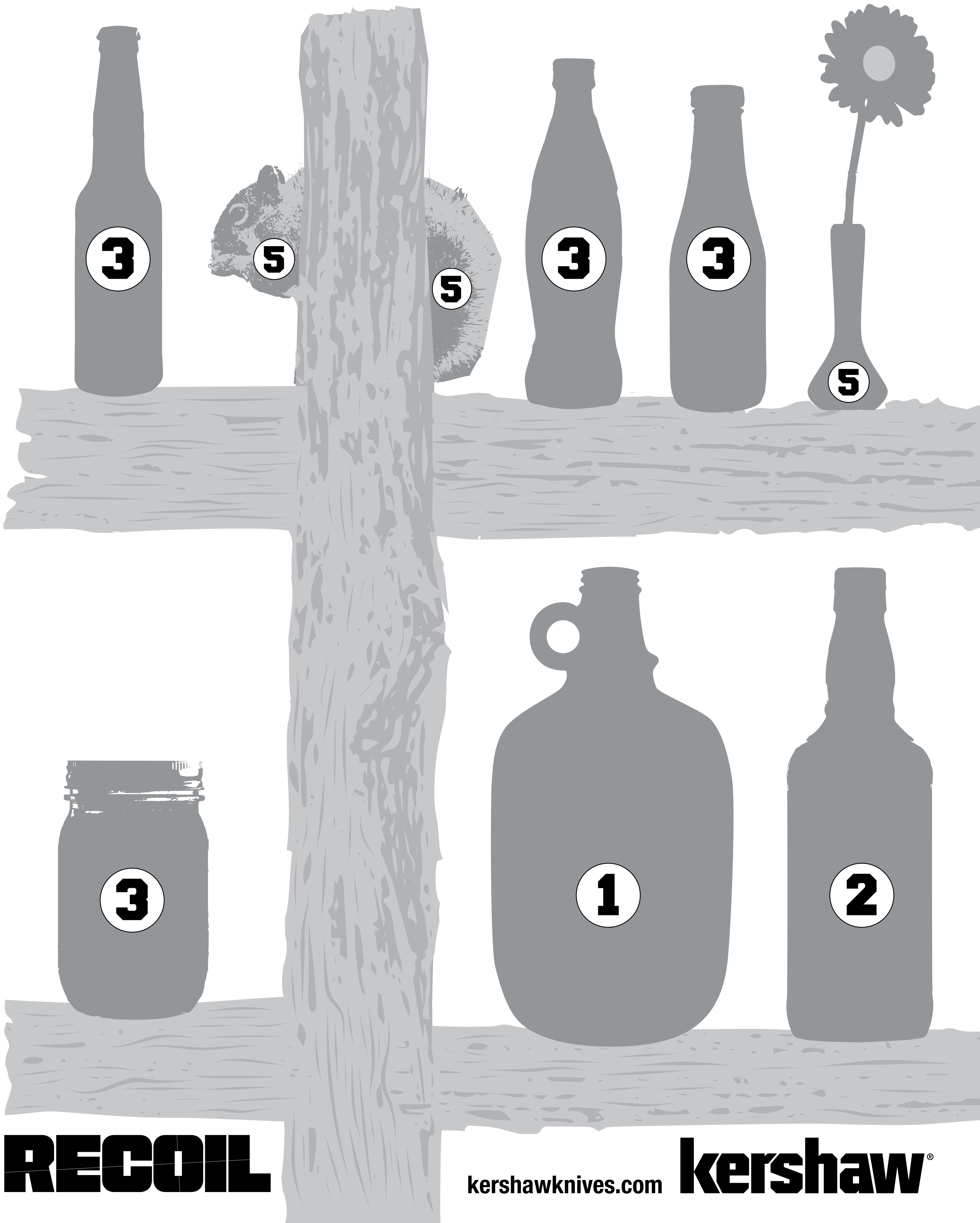

**RECOIL**

[kershawknives.com](http://kershawknives.com) **kershaw**<sup>®</sup>

**RECOIL  
RECOIL  
RECOIL  
RECOIL**

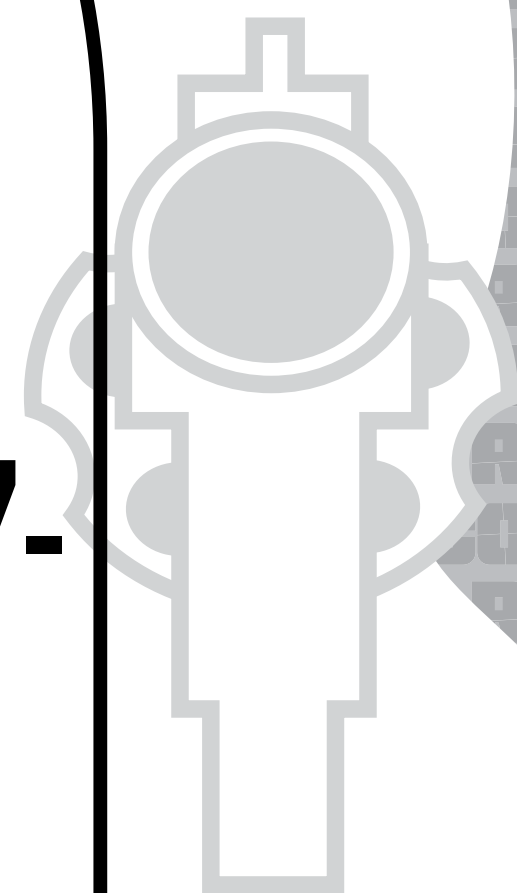
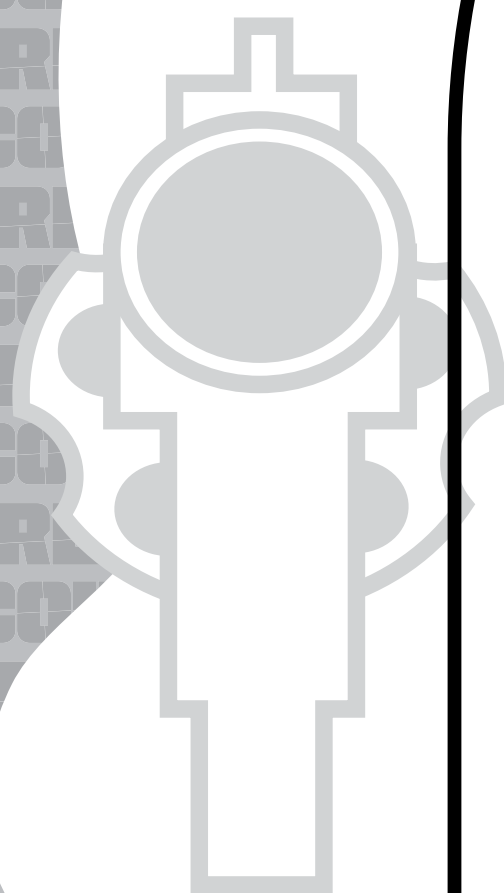
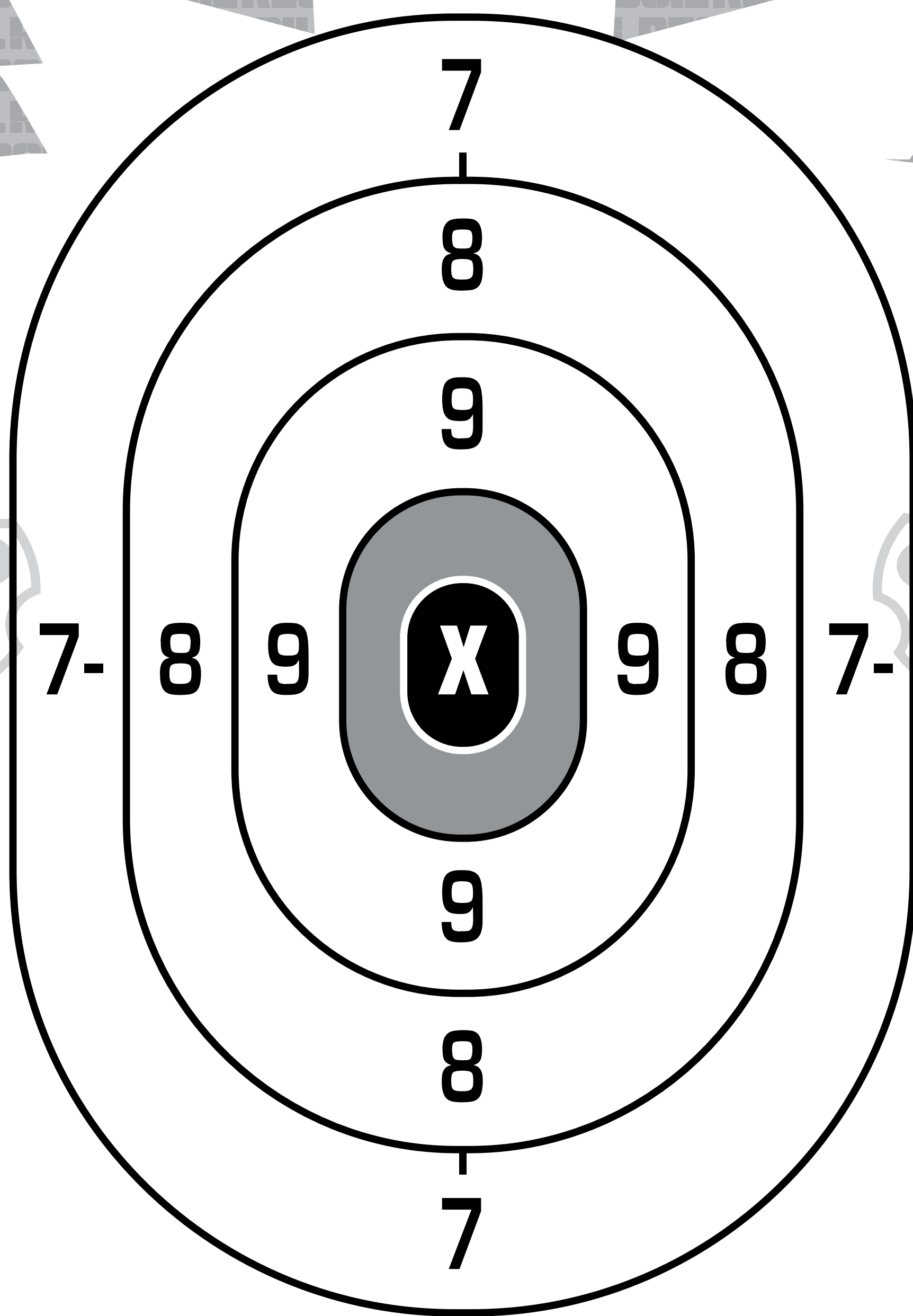

# LONG-RANGE SETUP TARGET

**B**

## LEVEL THE TARGET

Use a pin or nail to hang a plumb bob or weighted string to ensure target is perfectly vertical

**2**

« 2 MILS »

« 2 MILS »

**3**

« 2.5 MILS »

## ZERO AND CONFIRM ALIGNMENT

From 100 yards, zero your rifle and optic on circle A. Then follow these steps to confirm vertical alignment. Keep aiming at circle A for all shots throughout this exercise:

- » Dial your elevation knob up 2.5 mils and shoot a 3 shot group — they should impact on circle B.
- » Dial down 5 mils and shoot another 3 shot group — they should hit circle C.
- » Then dial back up 2.5 mils and shoot a 3 shot group on circle A.

« 2 MILS »

NOTE: THE BACKGROUND GRID IS LAID OUT IN 0.2 MIL INCREMENTS.

**A**

## BOX DRILL

This drill tests how accurate and repeatable your scope's turret adjustments are. Try this drill after you have zeroed your rifle at 100 yards. During this drill, always aim at circle A in the dead center of this target for all shots.

- » Dial your turrets down 2 mils and left 2 mils, then shoot a 3 shot group — it should impact in square 1.
- » Dial up 4 mils and shoot another 3 shot group — impacts should hit square 2.
- » Dial right 4 mils and shoot a 3 shot group — now impacts should be on square 3.
- » Dial down 4 mils and shoot a 3 shot group — they should hit square 4.
- » Finally, dial left 2 mils and up 2 mils, and shoot one more 3 shot group — this should impact in circle A.

« 2.5 MILS »

« 2 MILS »

**1**

## RETICLE SUBTENSION CHECK

From 100 yards, aim the center of your reticle at circle B. Verify that your 5 mil mark is at the center of circle C.

**4**

**C**

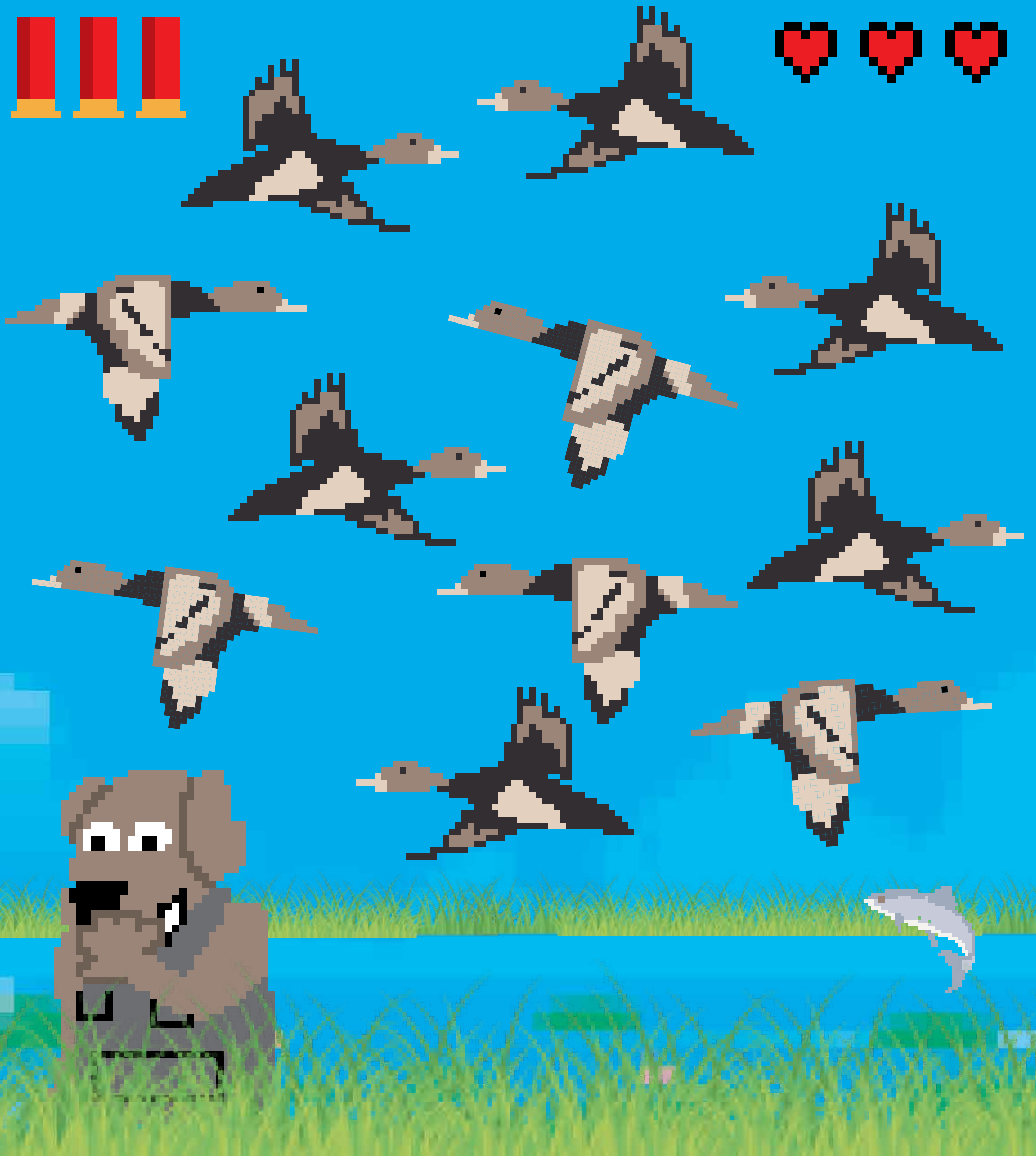
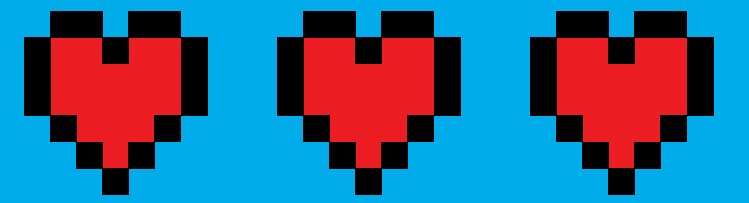
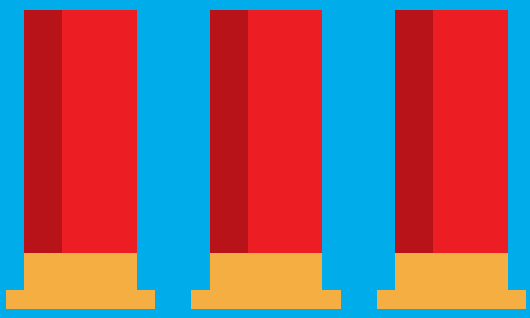

**FREE GIFT**  
For the first 1000 customers  
Use coupon code  
RECOIL38 at checkout



**PREPPER**  
G U N S H O P

**RECOIL**

SHARE YOUR SHOT TARGET WITH US    @PREPPERGUNSHOP

**PREPPERGUNSHOP.COM**

## 1. The Test

10 yards, ten shots, & ten seconds.

### Course of fire:

Shooter starts at the ready gun position (high or low). On signal, fire 10 rounds at the bullseye target, ceasing fire on the 10 second signal.

### Scoring:

10 ring = 10 points  
9 ring = 9 points  
8 ring = 8 points  
7 ring = 7 points

### Evaluation:

For ten shots the passing score is 90 points.  
If using a pistol with only 9 rounds (1911 .45 auto) possible is 90 points, passing score is 80.

If only 8 round capacity, possible is 80, 70 points is passing.

NOTE: If the pistol holds less than ten rounds, the start position will be from the holster.

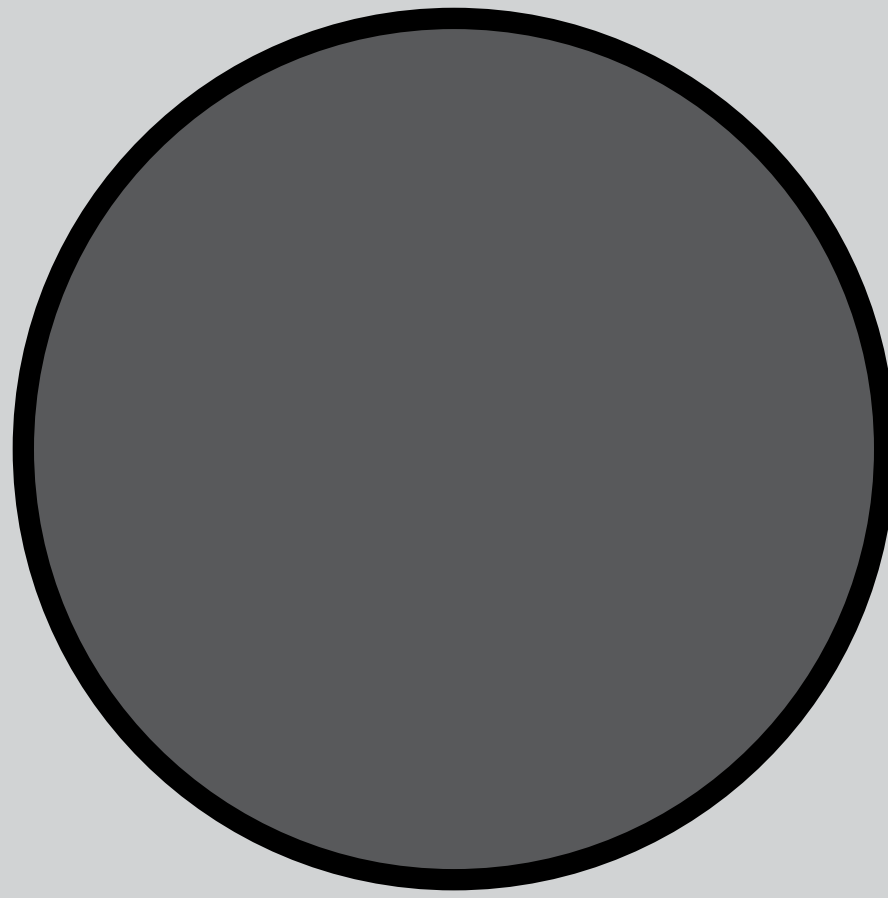

# COLT COMBAT UNIT™ HANDGUN SHOOTING DRILLS

## 2. The Wizard Drill

5 rounds total. Target is the 4.5" circle in the head and the complete bullseye target in the body.

### Course of fire:

Shooter starts with hands normal at side, with firing hand not touching the firearm.

1. At 3 yards, draw and fire one round on signal at the head, STRONG HAND ONLY. Time is 2.5 seconds.
2. At 5 yards, draw and fire one round on signal at the head. (Both hands allowed) Time is 2.5 seconds.
3. At 7 yards, draw and fire one round on signal at the head. (Both hands allowed) Time is 2.5 seconds.
4. At 10 yards, draw and fire two rounds at the bullseye target. (Both hands allowed) Time is 2.5 seconds.

### Scoring:

Rounds 1, 2, and 3:

Hits in the head zone 4.5" circle, subtract 0 points

Hits outside the circle, but still in the head, subtract 1 point

Round 4:

Hits inside the 7 ring, subtract 0 points

Hits outside the 7 ring, but still in the body, subtract 1 point.

For all rounds

Complete miss, subtract 5 points.

### Evaluation:

-2 points or less is a Pass

-3 points or more is a Fail

The goal is to pass from concealed carry or duty rig.

Do you have what it takes to successfully complete the Colt Combat Unit™ Handgun Shooting Drills? These drills were outlined by Ken Hackathorn to help you hone critical skills so they're sharp when you need them most.



BUILT ONE AT A TIME,  
PROVEN EVERY ROUND™



RECOIL



# CONSISTENCY SILHOUETTE

WARM UP 1

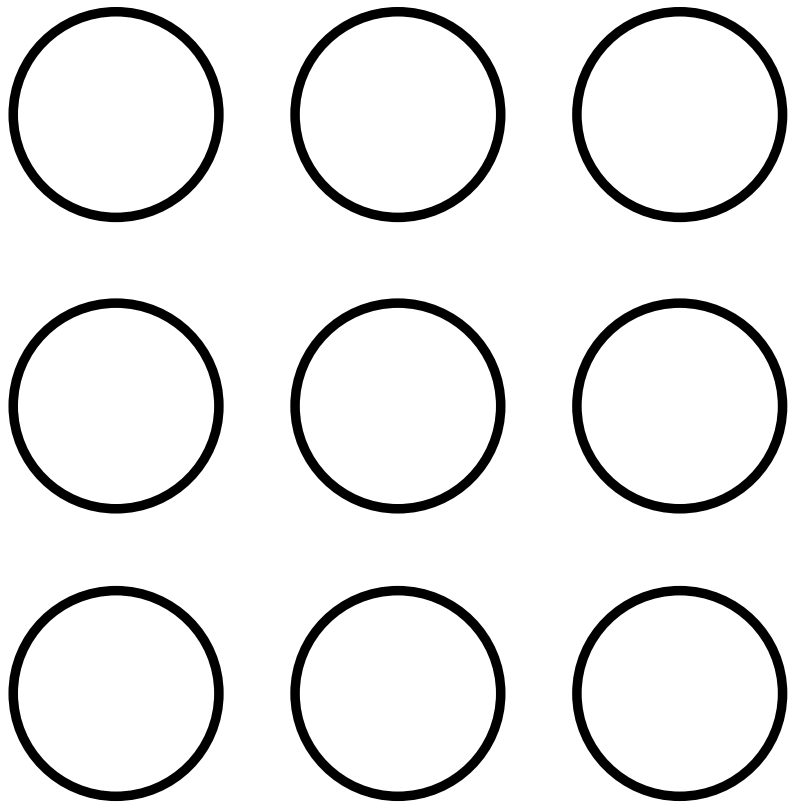

COOL DOWN

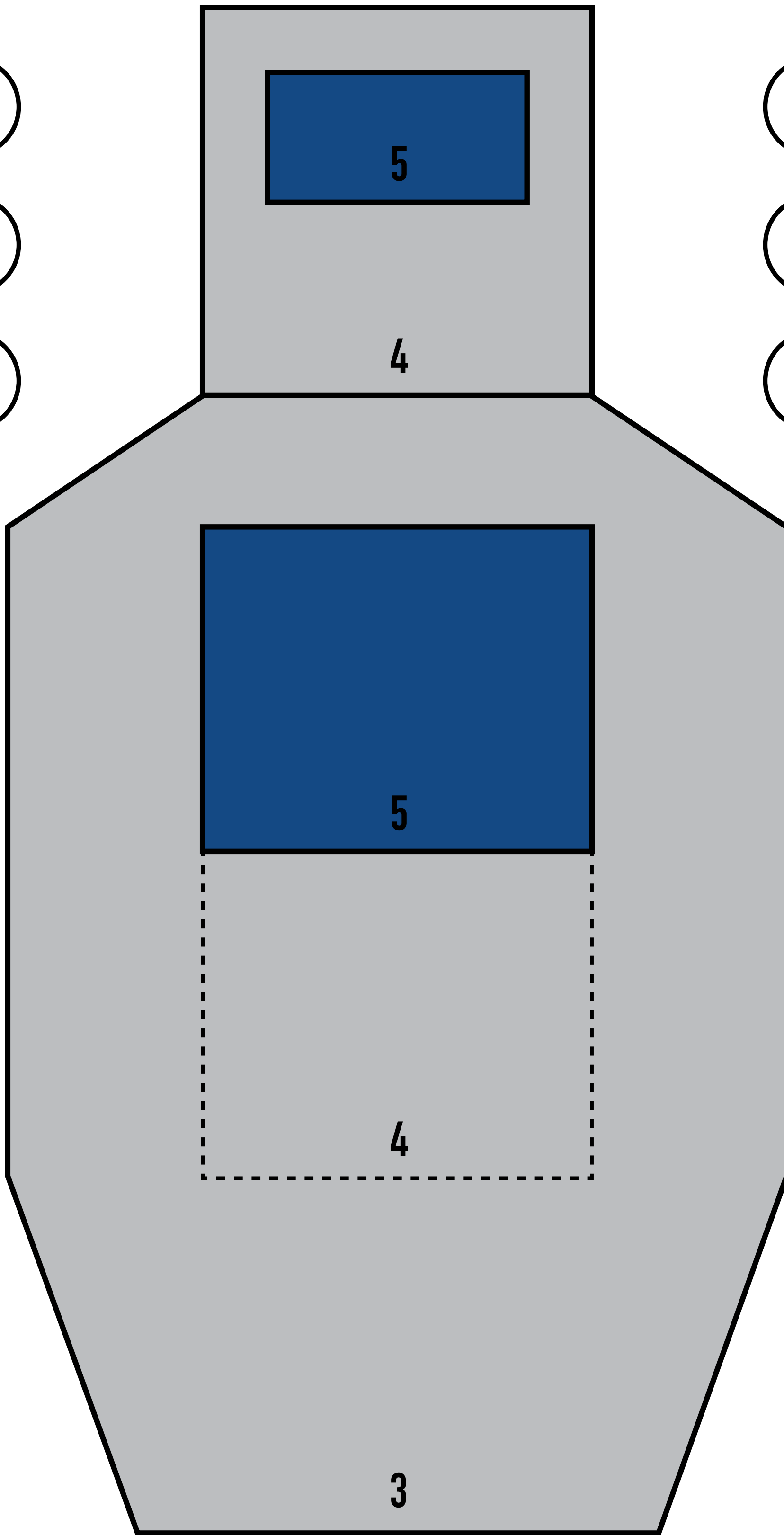
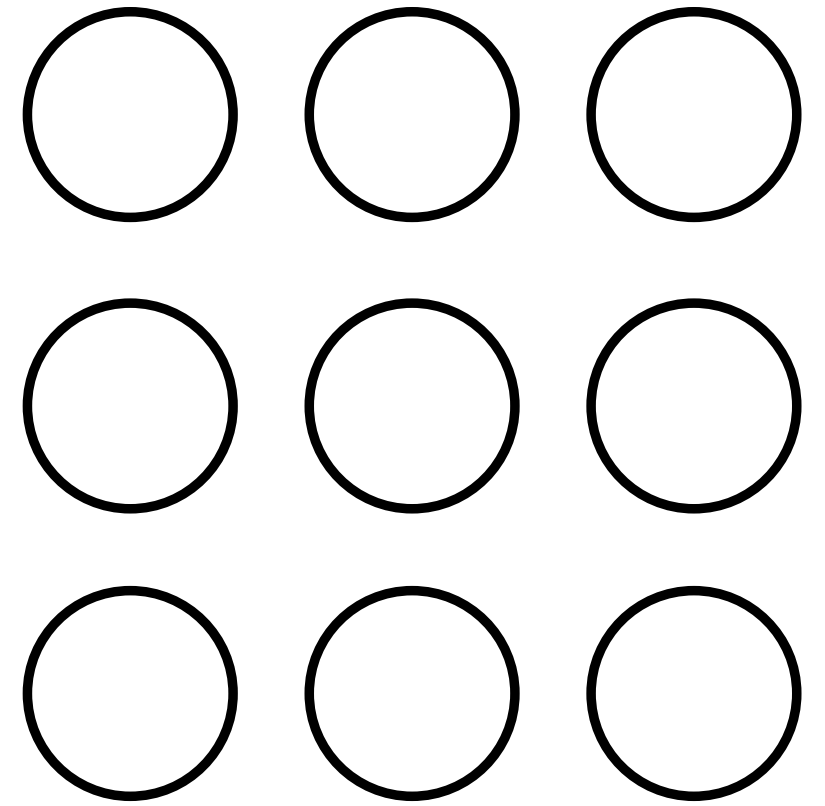

WARM UP 2

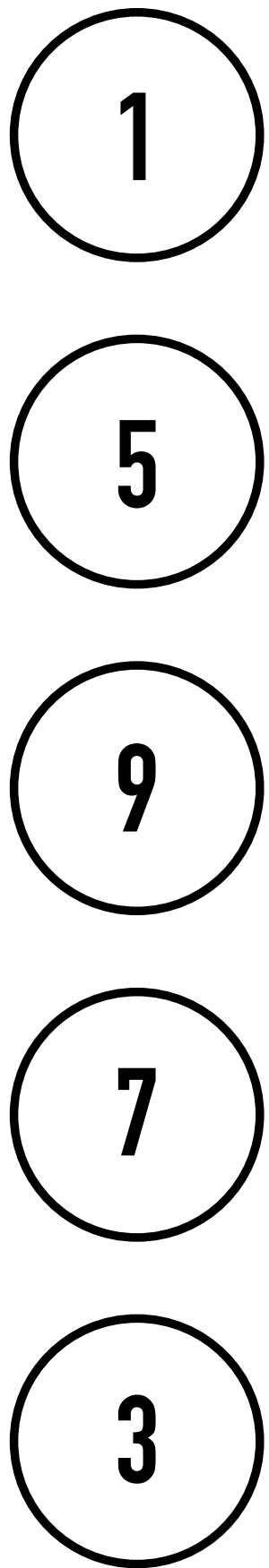

WARM UP 2

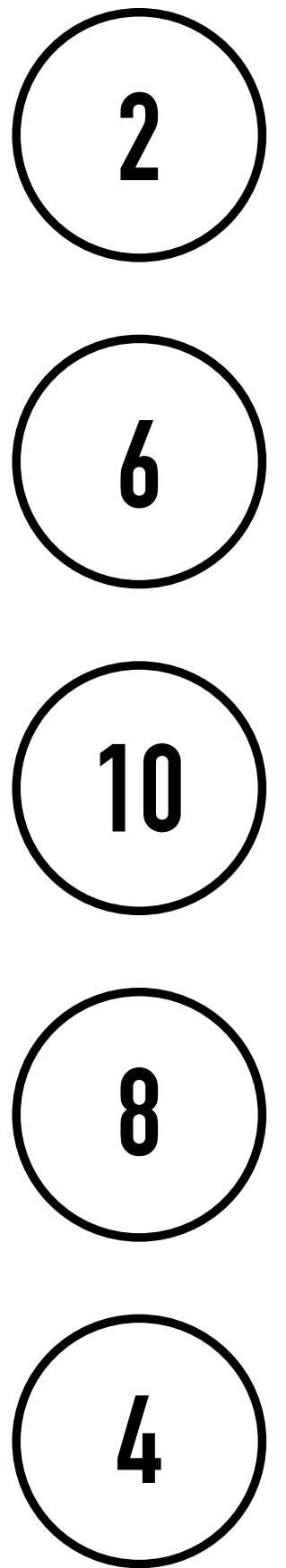

**WARM UP 1 / COOL DOWN**

Shoot from left to right, top to bottom. One bullet per circle. Take make-up shots as necessary. Shoot at a minimum distance of three yards.

**WARM UP 2**

Shoot on target one and shoot sequentially to target ten. Two bullets per circle. Take make-up shots as necessary. Shoot at a minimum distance of three yards.

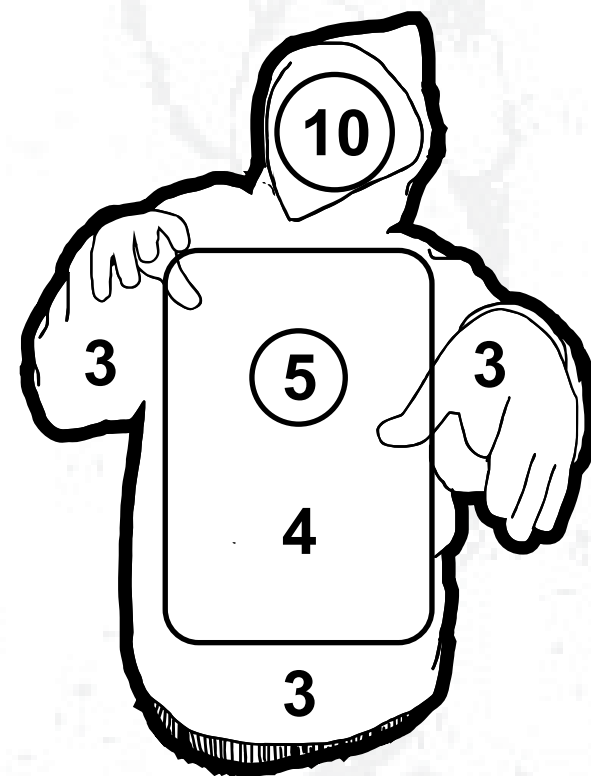
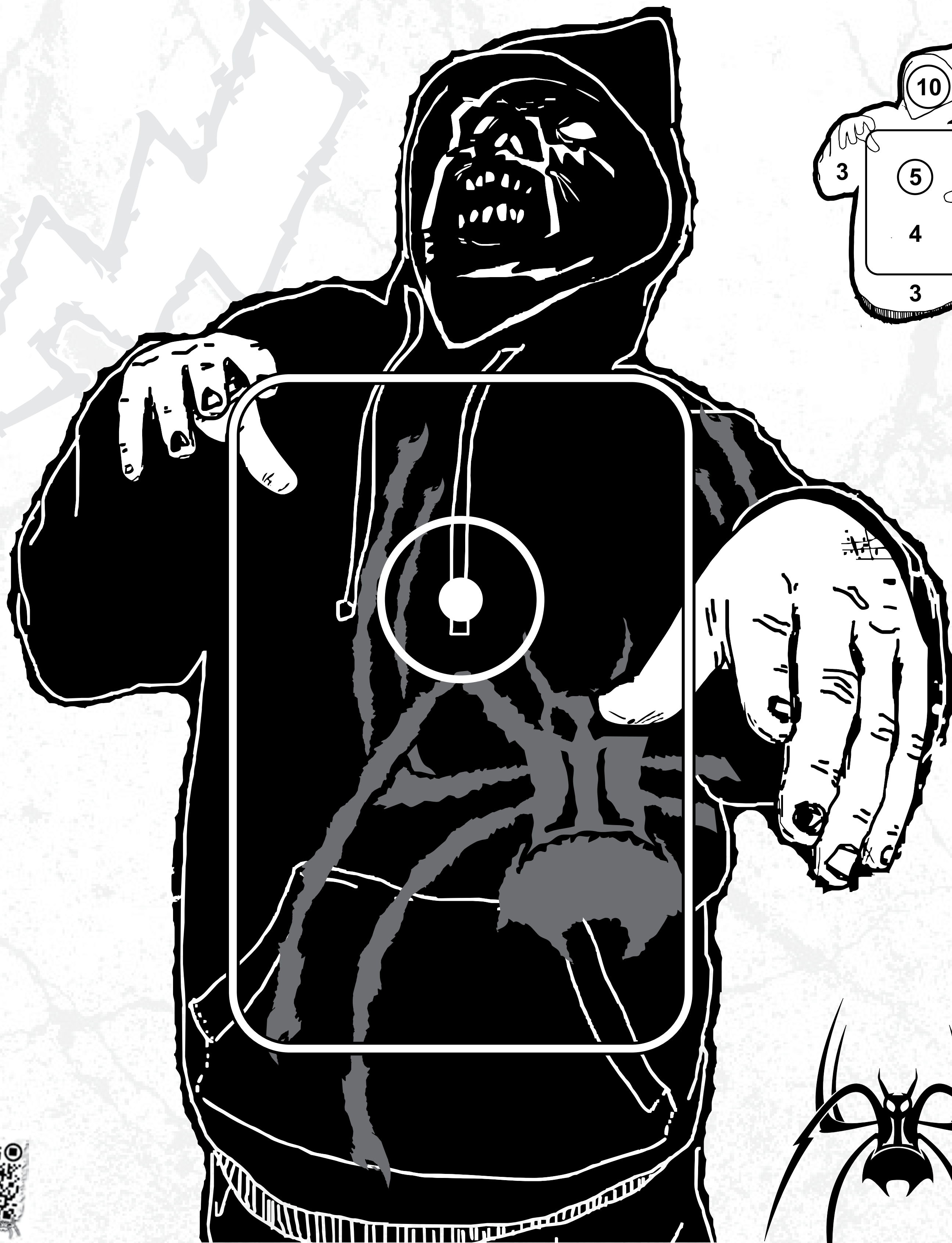

**RECOIL**

**SPIKES TACTICAL.COM**

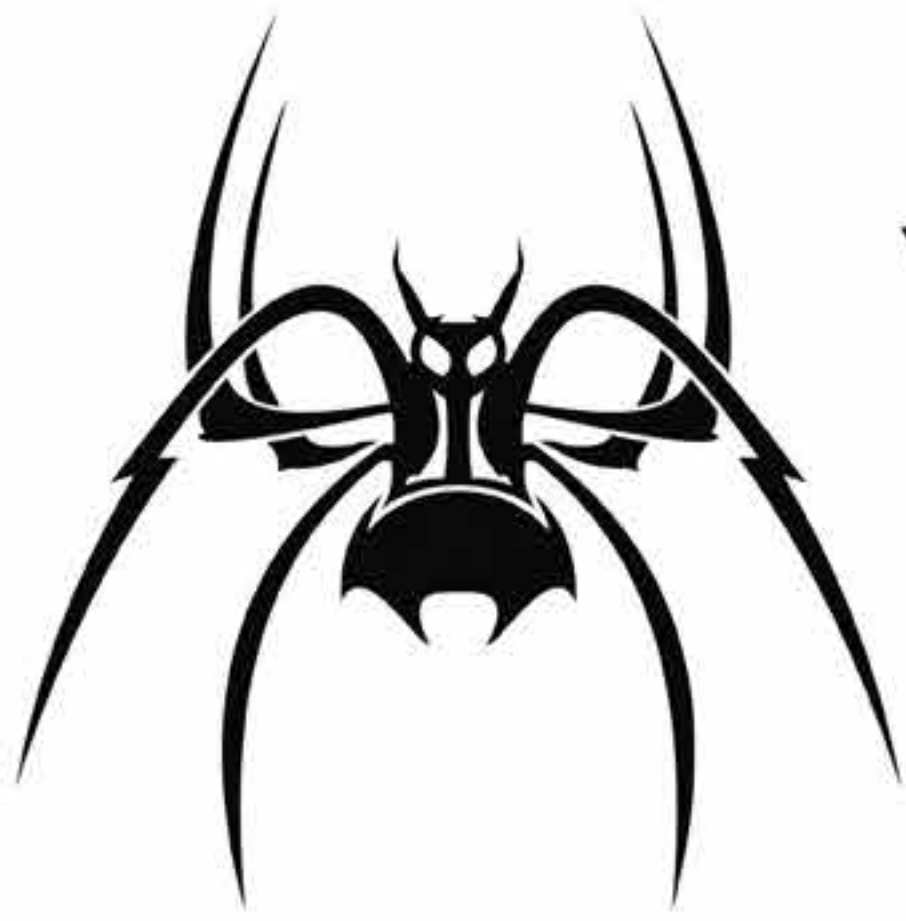

WWW.SPIKESTACTICAL.COM

ZERO IN

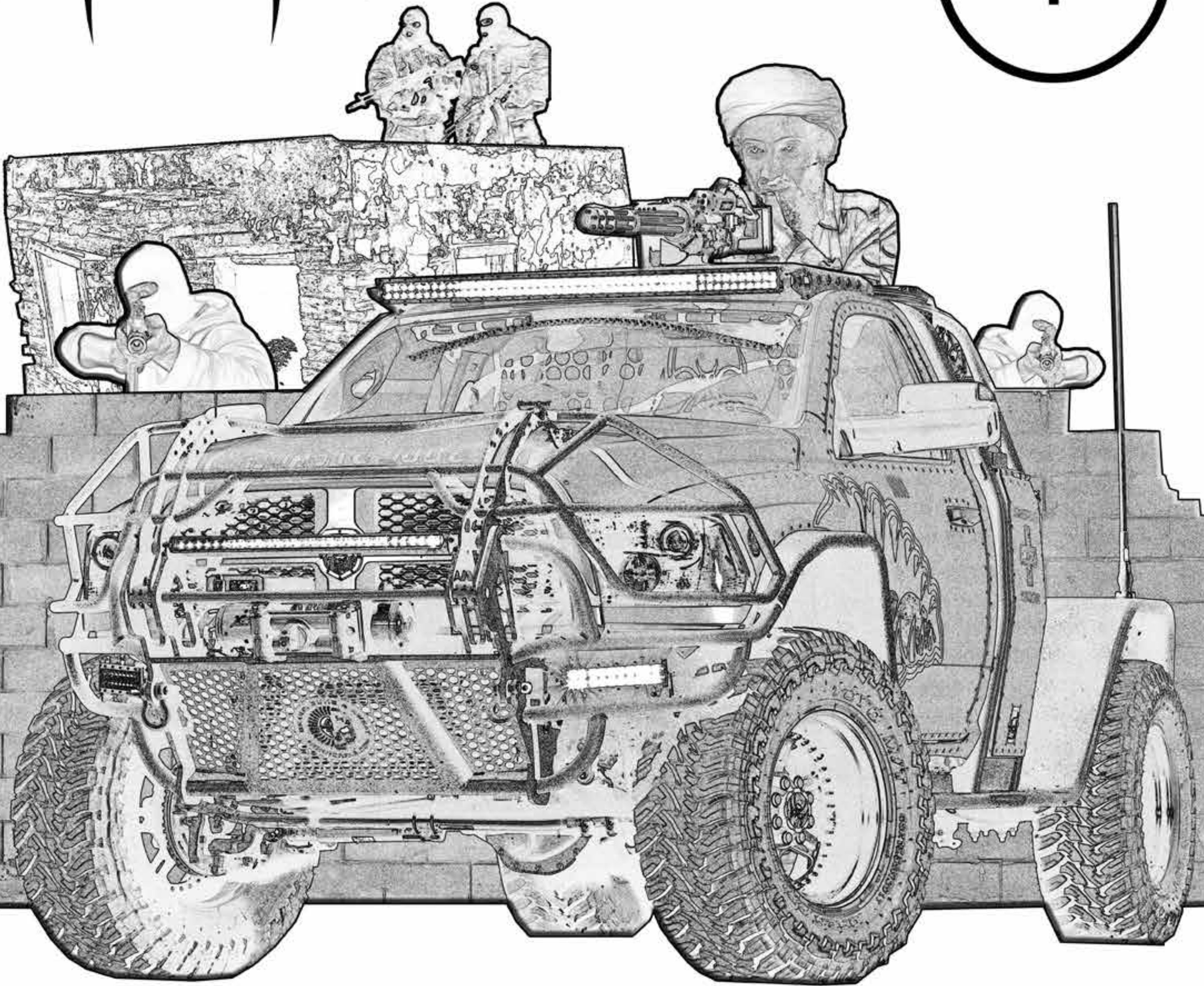
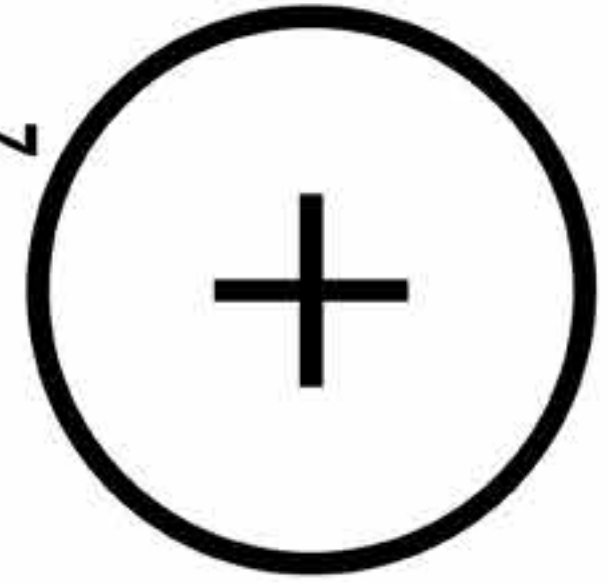

RECOVER SPIKES TRUCK  
WITH HEAD SHOTS

**RECOIL**

POST YOUR RESULTS -->





Photo by Jorge Alvarez, iStockphoto.com, ATLANTE, BlueRAM, iStockphoto.com

**RECOIL**  
**RECOILWEB.COM**

Don't become an online zombie reading the same old same old. Check out the lively OFFGRIDweb.com. This new site is packed with tips and tutorials to help you prepare for any disaster, whether manmade or natural. It takes a fresh look at urban survival by providing first looks at the latest gear, honest hands-on product reviews, and in-depth techniques from the experts — all brought to you by the same team who produces RECOIL.

**RECOIL OFFGRID**  
**OFFGRIDWEB.COM**

ONE SHOT/ONE DOT

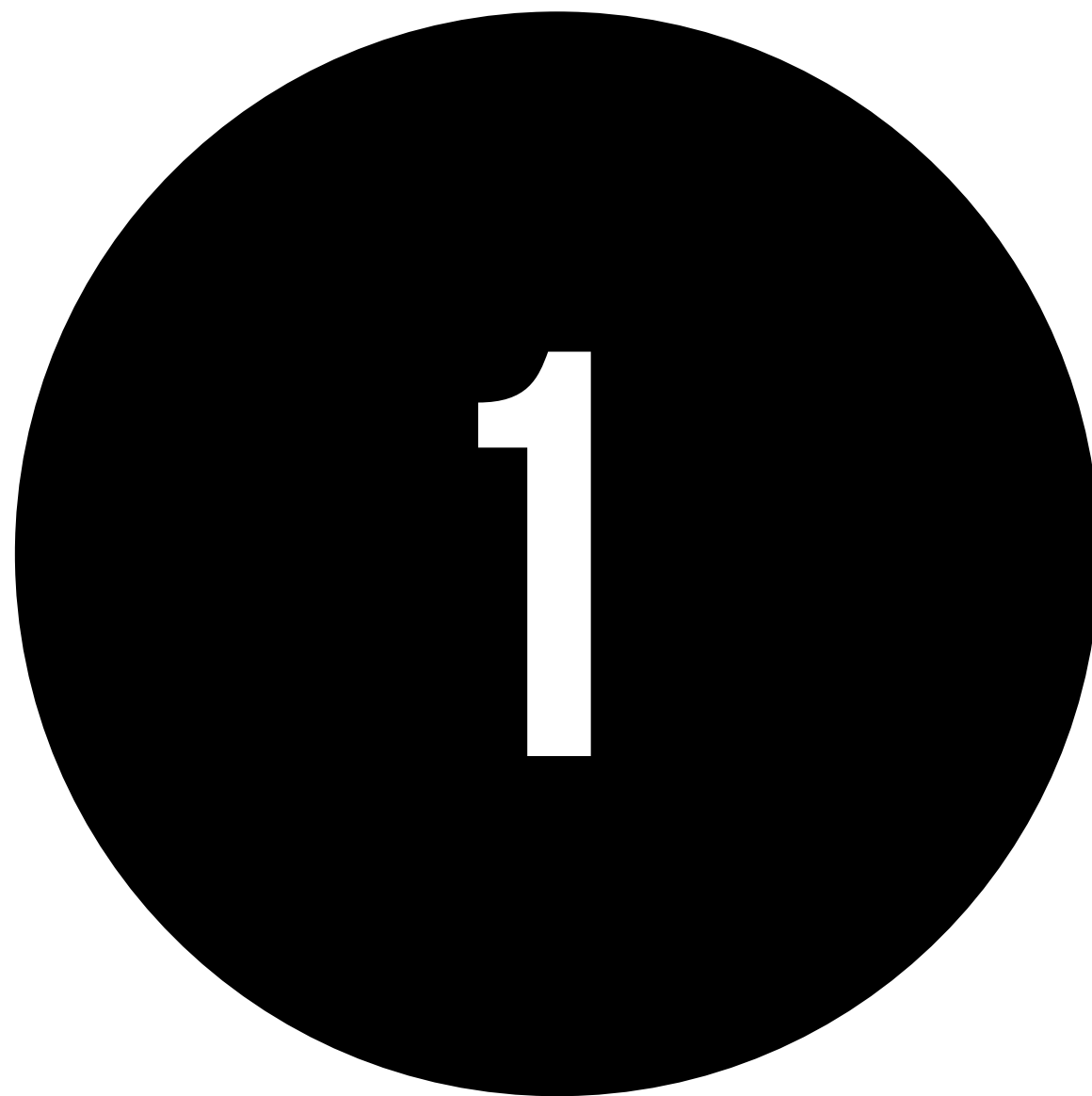

WE FOCUS ON THE FUNDAMENTALS.

**RECOIL**

**NRACARRYGUARD17.COM**  
**1-866-NRA-4040**

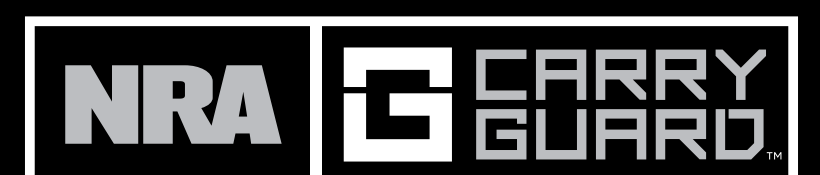

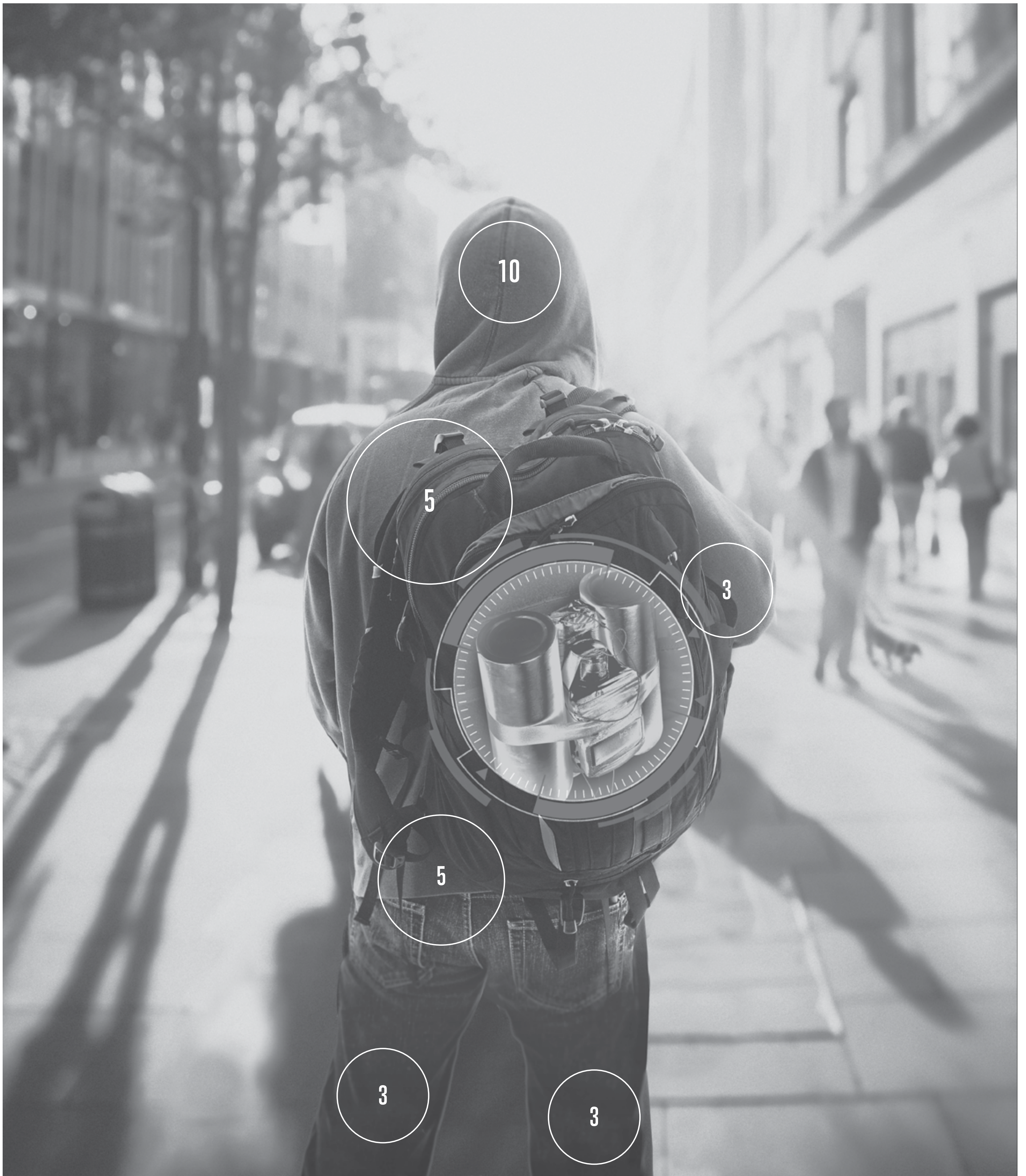

**RECOIL**  
RECOILWEB.COM

Don't become unprepared by reading the same old same old. Check out OFFGRIDweb.com. Our site is packed with tips and tutorials to help you prepare for any disaster, whether manmade or natural. It takes a fresh look at urban survival by providing first looks at the latest gear, honest hands-on product reviews, and in-depth techniques from the experts — all brought to you by the same team that produces RECOIL.

**RECOIL OFFGRID**  
OFFGRIDWEB.COM

**SEE HOW YOU STACK UP WITH LAV!**

**5 SHOTS, 50M STANDING OFFHAND**

**LARRY'S GROUP SHOT WITH:**

- » DDM4 V5 RIFLE
- » AIMPOINT® MICRO T-1 4 MOA DOT
- » GEISSELE SSA TRIGGER
- » BLACK HILLS 55gr. FMJ



Watch "LAV'S RECOIL" on  
Daniel Defense's YouTube Channel:  
<http://www.youtube.com/user/danieldefense>

» Also visit Larry Vickers' site at [vickerstactical.com](http://vickerstactical.com)



# RECOIL

# DANIEL DEFENSE®

» LIGHTER, STRONGER, BETTER.®

» 866.554.GUNS » DANIELDEFENSE.COM

Each target represents 1 MOA at its stated distance.  
See how different firing positions affect your accuracy!

# RECOIL

300Y

300Y

KNEELING

PRONE

200Y

STANDING

KNEELING

PRONE

100Y

STANDING

KNEELING

PRONE

BONUS:  
STANDING  
SUPPORT SIDE

# DANIEL DEFENSE

» LIGHTER. STRONGER. BETTER...®



INTRODUCING THE REVOLUTIONARY **DD5**™

When we set out to create a .308/7.62mm rifle fit to wear the Daniel Defense name, we cleared the drawing board and created an entirely new evolution of the AR-10 platform. Packed full of innovative features that enhance comfort, durability and performance while still possessing the legendary handling and quality of our DDM4 carbines.

Visit [DanielDefense.com](http://DanielDefense.com) for all of the details, and see the new DD5 at your local Daniel Defense dealer.



5.11 

# TPD DRILL

TIME, PRECISION, DISTANCE.  
CONCEALED CARRY SKILL BUILDER



## DRILL INSTRUCTIONS

- Dots are numbered for distance. Shoot the 3 dot from 3 yards, 5 dot from 5 yards, etc.
- Fire 2 rounds at each target from the prescribed distance.
- Par times are the same for all distances.
- From concealed holster: 4 seconds.  
From low-ready: 2.5 seconds

Complete this drill for a chance to win  
\$511 dollars worth of gear - details below.

# RECOIL



**ALWAYS BE READY**

Shoot the drill and post a picture of your target on Instagram.  
Tag @511tactical and use the hashtag #alwaysbeready for a chance to win.  
We'll give away \$511 dollars in 5.11 gear to three lucky winners.

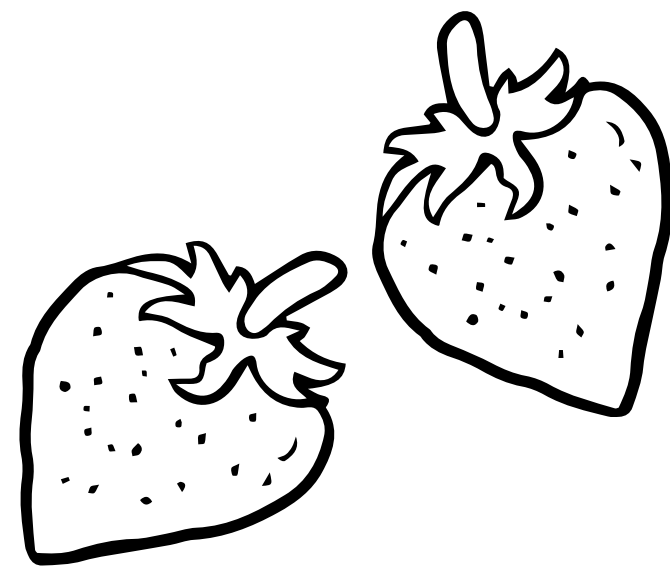
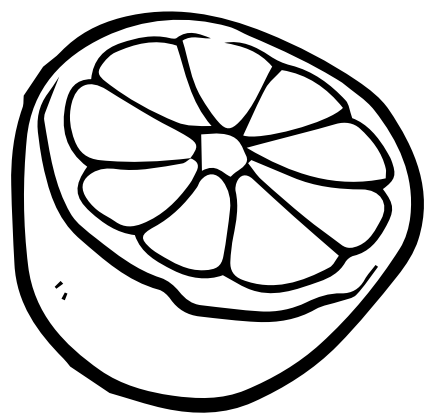
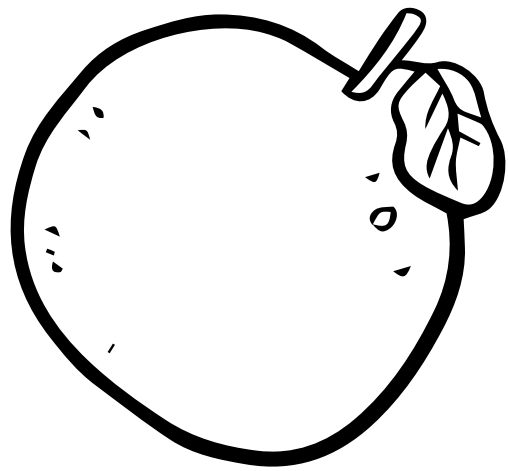

# SOG

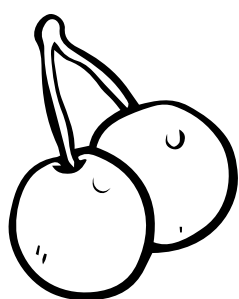
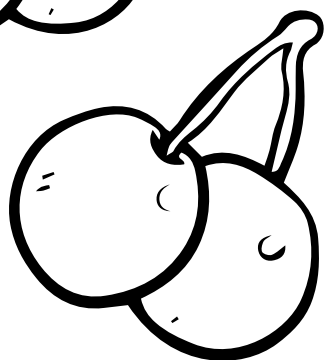
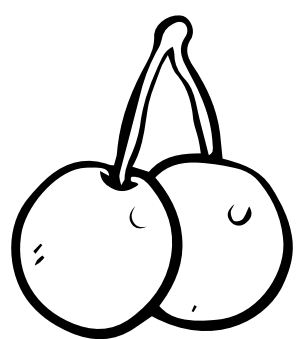
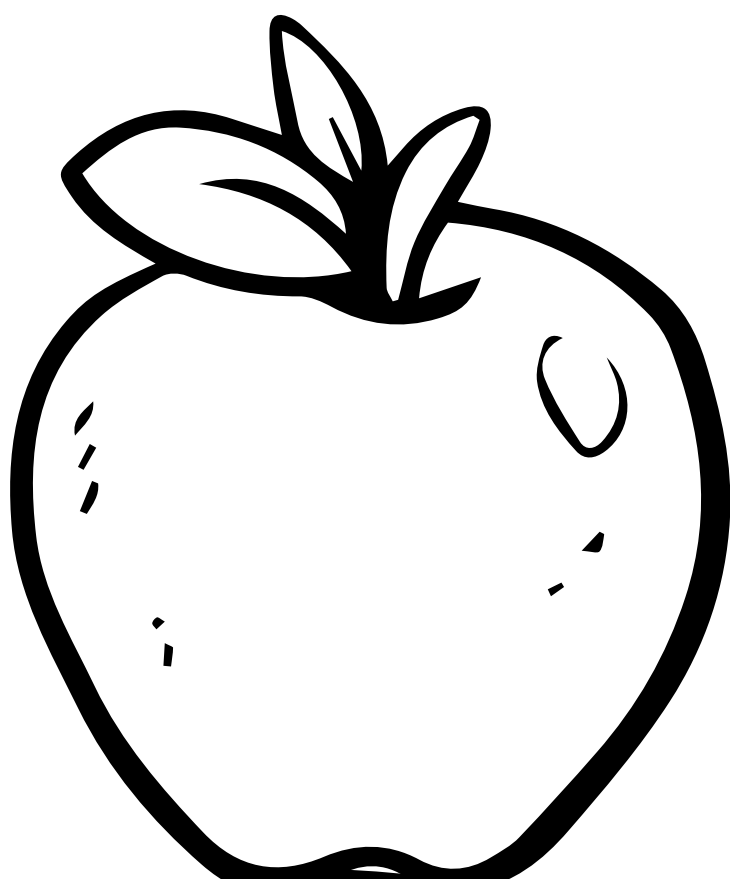
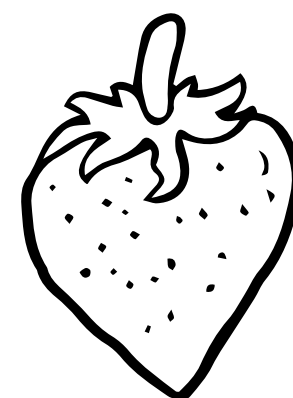

# RECOIL



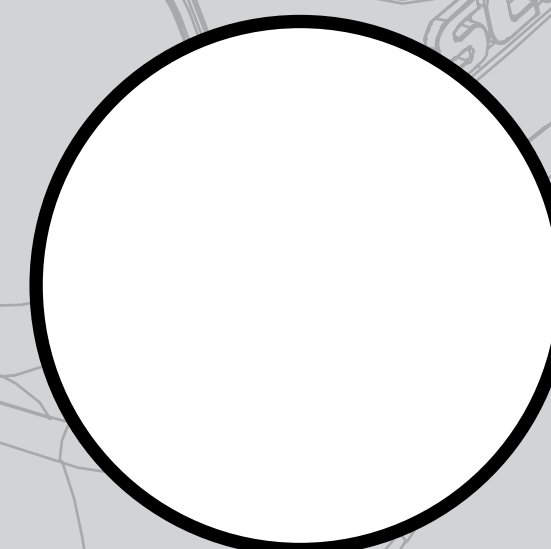
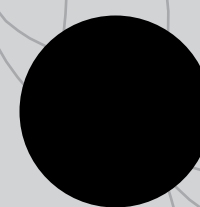
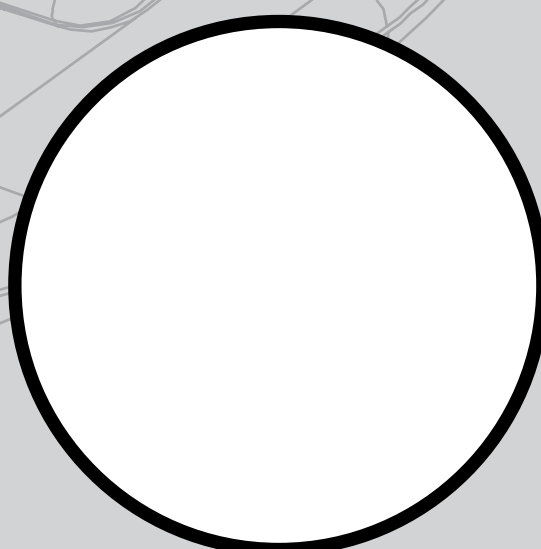
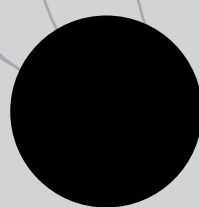
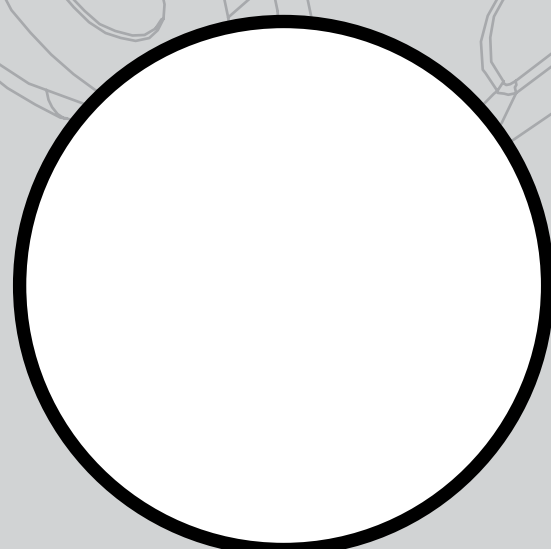
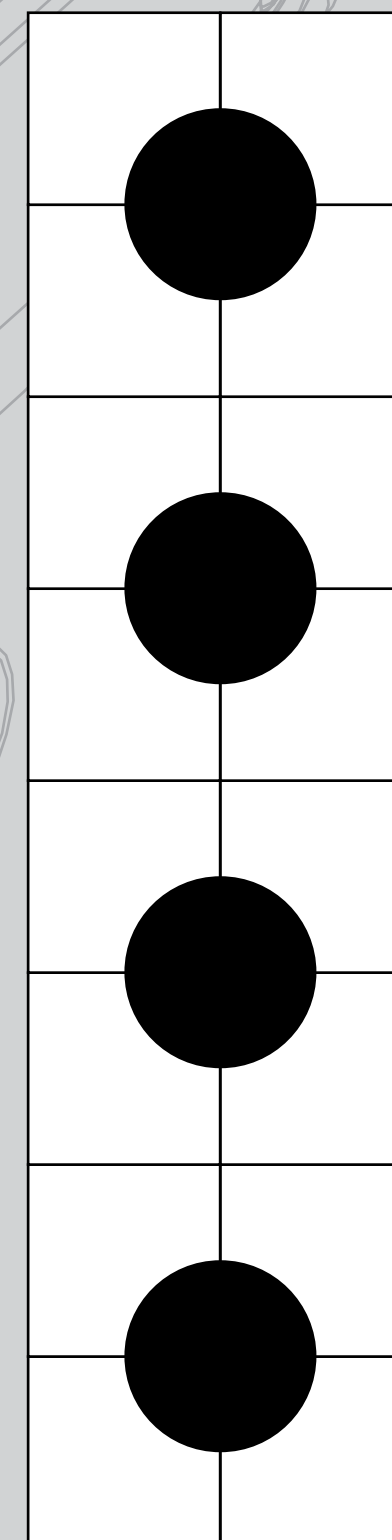
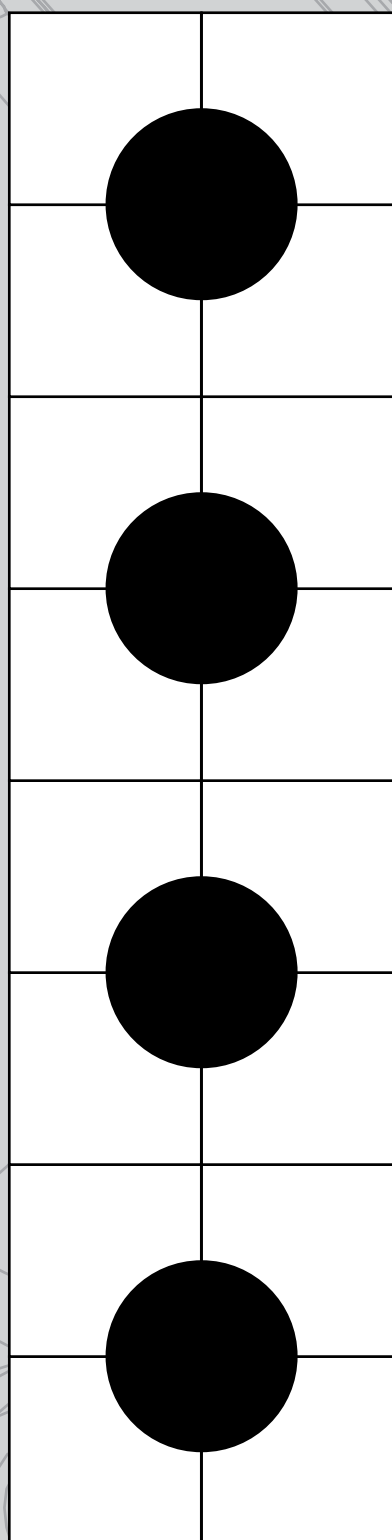
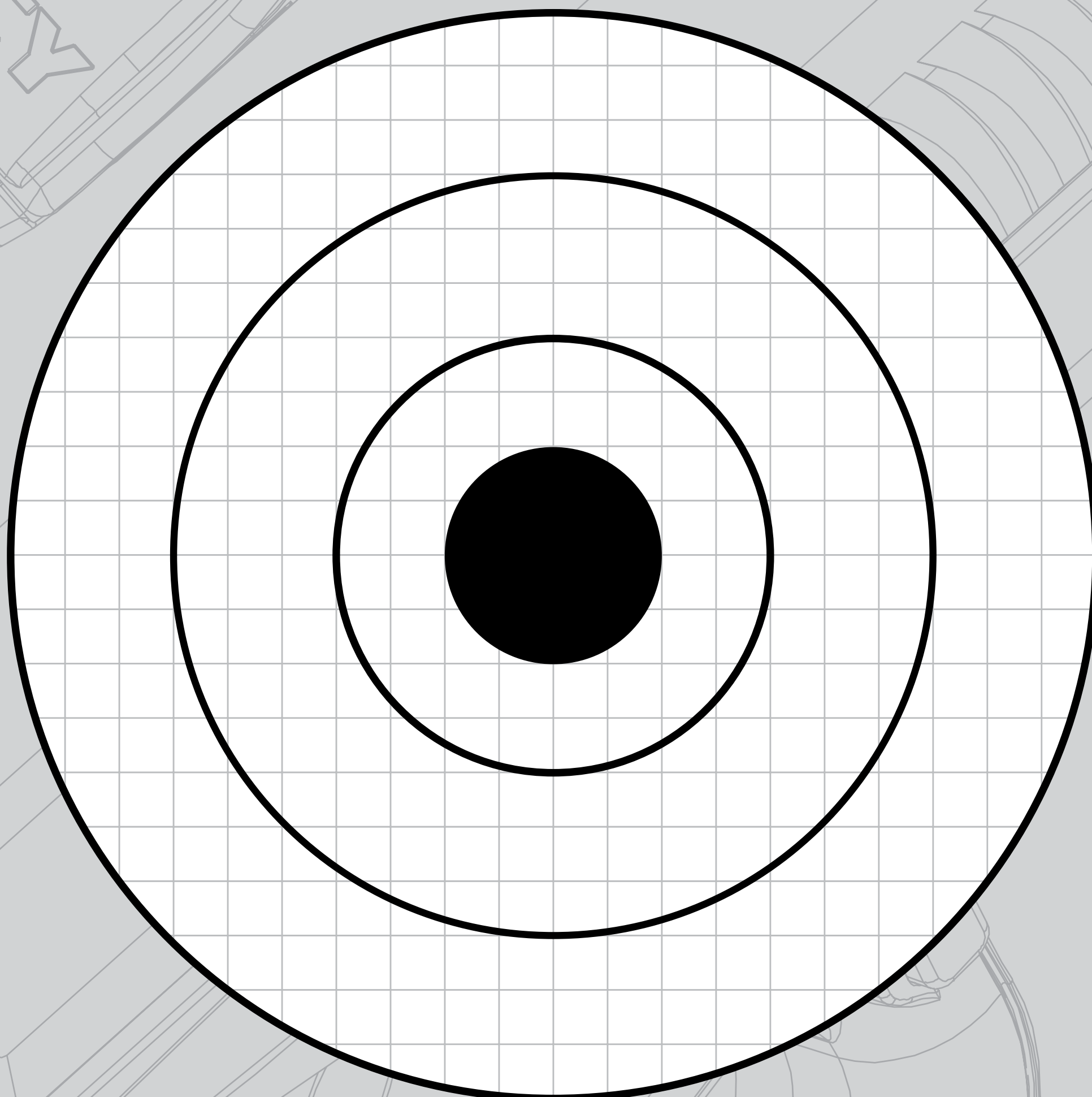
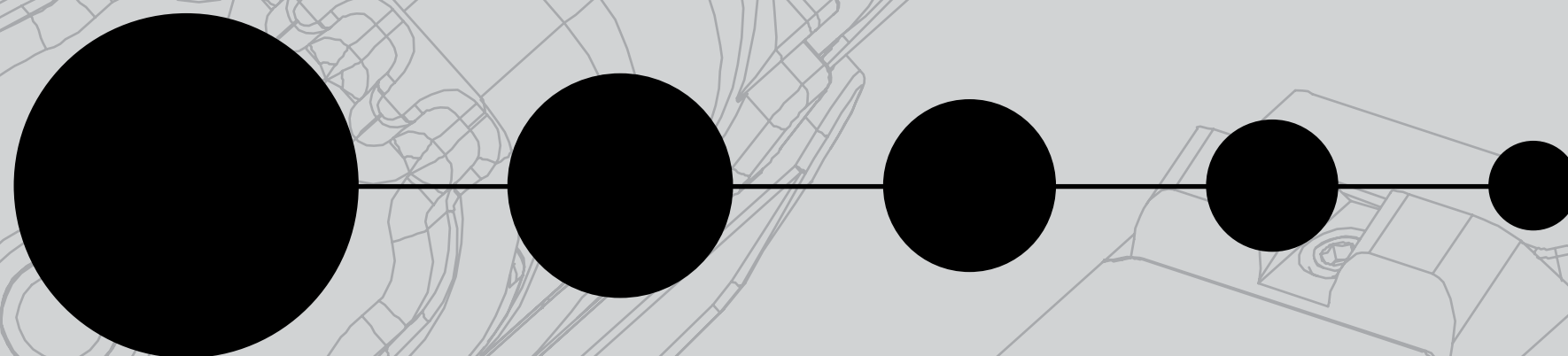

**SCCY PAPER TARGET DRILLS** FOR HANDGUN DRILLS PLACE TARGET AT 7 YARDS (21 FEET). FOR EVERYTHING ELSE, HAVE SOME FUN AND SHOOT THIS PAPER!

**DRILL 1:** FIRE CONSECUTIVE SHOTS AIMING AT THE CIRCLES LARGEST TO SMALLEST, LEFT TO RIGHT, AT THE TOP OF THIS TARGET. IF YOU MISS ONE OF THE CIRCLES, TARGET AND FIRE AGAIN. COMPLETE WITH THE FEWEST ROUNDS POSSIBLE.

**DRILL 2:** USE LARGE ROUND TARGET AND SIDE SQUARE TARGETS TO BUILD ACCURACY. START IN THE MIDDLE WITH THE ROUND TARGET AND WORK TOWARDS SQUARES.

**DRILL 3:** FIRE CONSECUTIVE SHOTS, PLACING TWO ROUNDS PER LARGE CIRCLE AND ONE ROUND PER SMALL BLACK CIRCLE. ONLY MOVE TO THE NEXT CIRCLE ONCE YOU HIT THE TARGET WITH THE PROPER NUMBER OF ROUNDS. IF YOU MISS, TARGET AND FIRE AGAIN. DON'T MOVE FORWARD UNTIL YOU HAVE PLACE THE PROPER NUMBER OF ROUNDS. COMPLETE WITH THE FEWEST ROUNDS POSSIBLE.

**SCCY** /SKAI/

NOUN

- 1. A MANUFACTURER OF SUBCOMPACT HAND GUNS.
- 2. FIND OUT MORE @ [WWW.SCCY.COM](http://www.sccy.com)

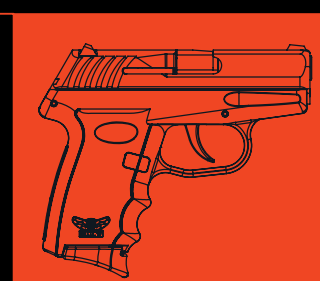

WWW.BLADE-TECH.COM

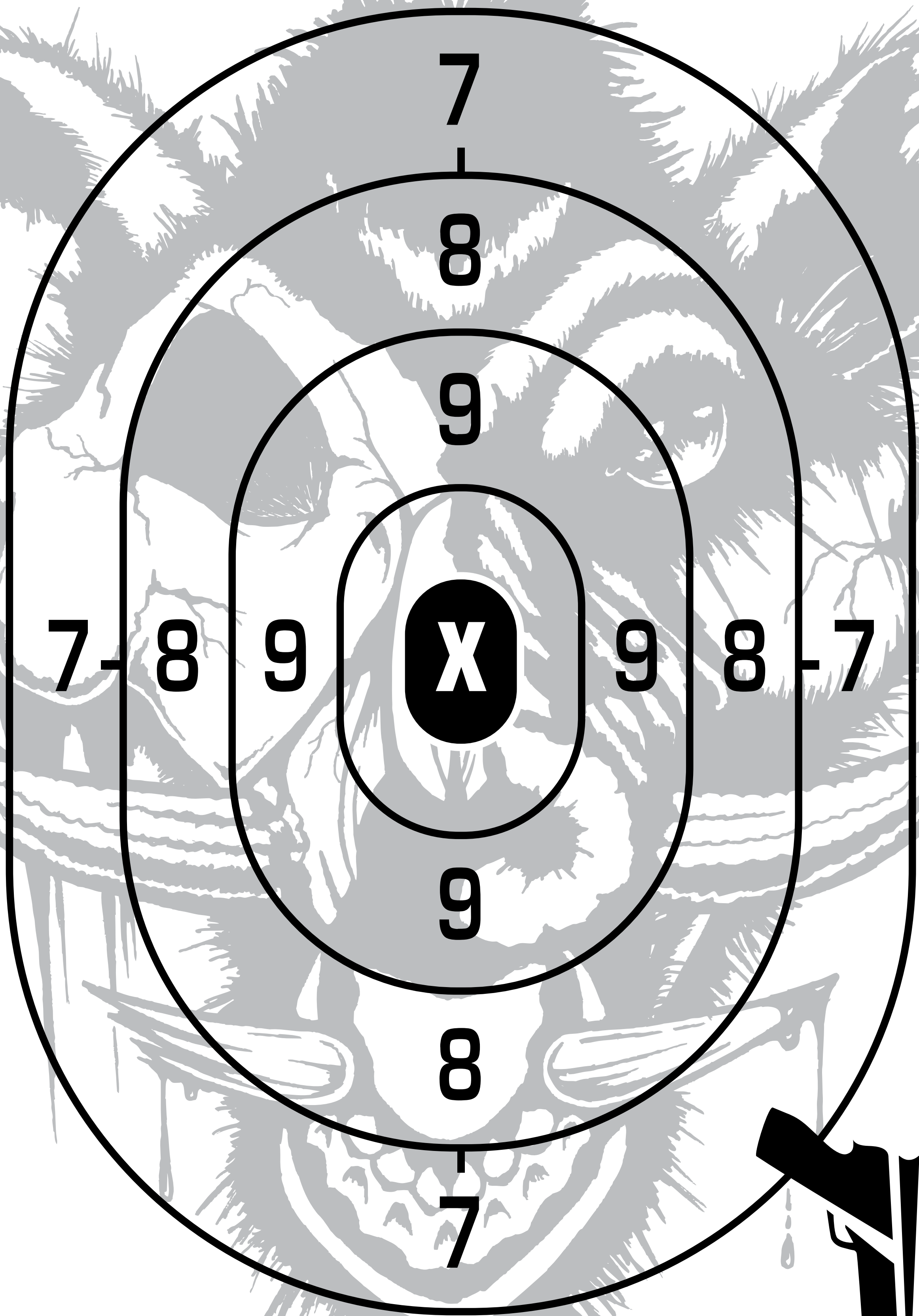

**RECOIL**

**BLADE-TECH**<sup>TM</sup>  
CARRY CONFIDENT

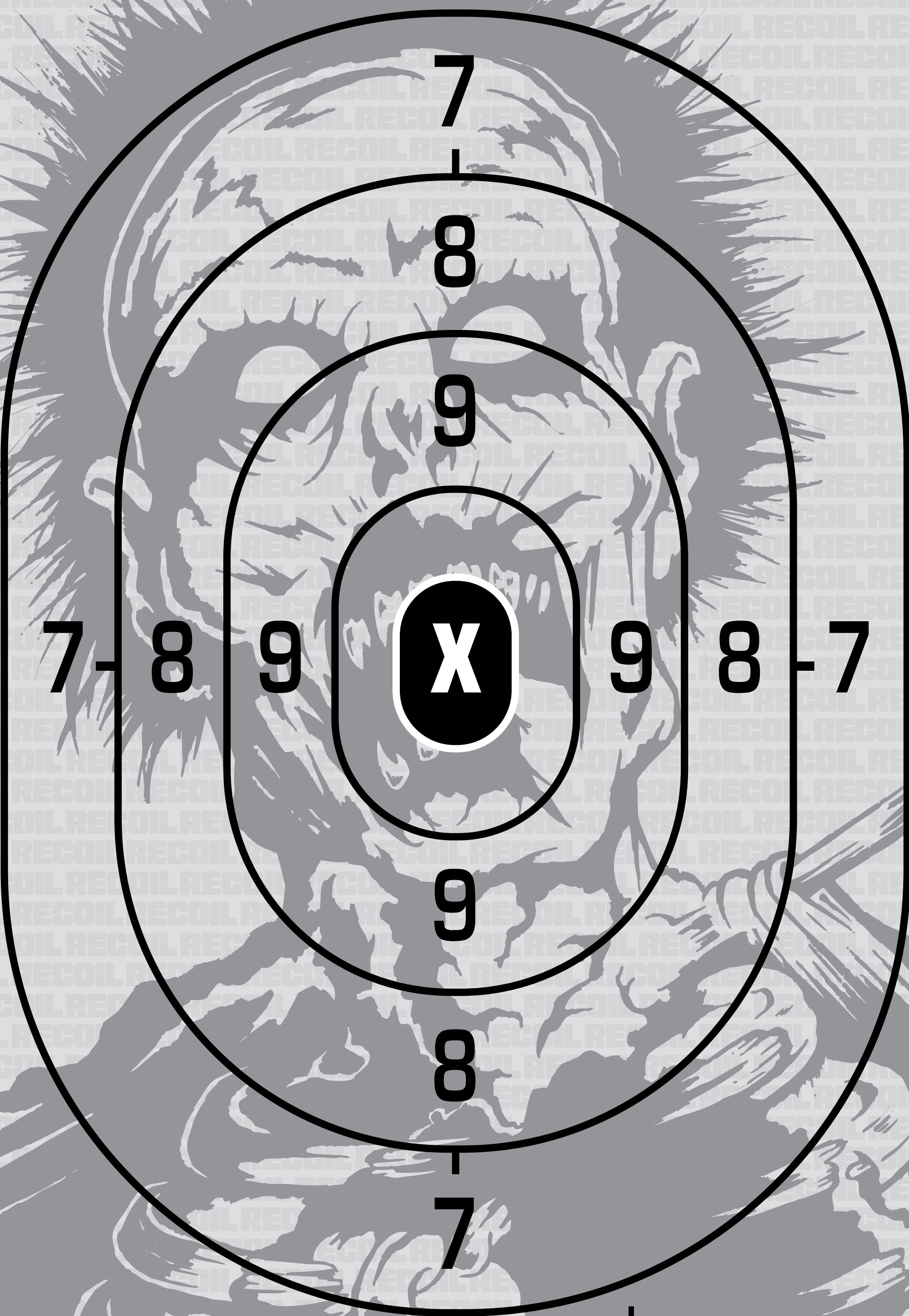

**RECOIL**



**MFT**  
MISSION FIRST  
TACTICAL  
MADE IN THE USA • [WWW.MISSIONFIRSTTACTICAL.COM](http://WWW.MISSIONFIRSTTACTICAL.COM)